

Storm Water Management And Erosion Control Ordinance

With
Appendix D Minor Land Disturbance Erosion
Control Permit Technical Manual
Appendix E Major Land Disturbance Erosion Control
Permit Technical Manual
Appendix F Standard Details

Adopted
June 18, 2015

Champaign County, Illinois

This Storm Water Management and Erosion Control Ordinance is part of Champaign County's National Pollutant Discharge Elimination System (NPDES) Municipal Separate Storm System (MS4) program to comply with State and Federal requirements for storm water discharge.

Table of Contents

1.0	AUTHORITY	1
1.1	Title	1
1.2	Illinois Compiled Statutes.....	1
2.	PURPOSE	1
3.	DEFINITIONS	1
4.	SCOPE	9
4.0	Applicability.....	9
4.1	General Exemptions.....	10
4.2	Storm Water Drainage Plan Exemptions.....	11
4.3	LDEC Permit Exemptions	12
5.	AUTHORIZATIONS AND PROJECT TERMINATION	13
5.0	Approval Authorities.....	13
5.1	Authorizations	13
5.2	Project Termination.....	14
6.	PROTECT EXISTING DRAINAGE AND WATER RESOURCES	14
6.1	General Requirement.....	14
6.2	Natural Drainage.....	15
6.3	Agricultural and Other Drainage Improvements	15
6.4	Minimum Erosion Control and Water Quality Standards.....	16
6.5	General Enforcement	17
6.6	DEMOLITION PERMIT and GRADING PERMIT	17
7.	EASEMENTS	21
8.	STORM WATER DRAINAGE SYSTEM	21
8.1	Minor	21
8.2	Major.....	21
8.3	Hierarchy of Best Management Practices	21
9.	STORM WATER DRAINAGE PLAN	22
9.1	General Design.....	22
9.2	Dry Bottom Storm Water Storage Areas.....	23
9.3	Wet Bottom Storm Water Storage Areas.....	25
9.4	Alternative Storm Water Storage Areas.....	25
9.5	Submittals.....	26

Champaign County, Illinois
Storm Water Management and Erosion Control Ordinance

9.6	Certifications	26
10.	JOINT CONSTRUCTION.....	27
11.	LAND DISTURBANCE EROSION CONTROL	27
11.1	General Requirement.....	27
11.2	Minimize Soil Erosion	27
11.3	Minimize Sedimentation	28
11.4	Construction Dewatering.....	28
11.5	Stockpiles	28
11.6	Required Maintenance of Erosion and Sediment Control Measures	28
12.	LDEC PERMITS.....	29
12.0	Applications for a LDEC Permit.....	29
12.1	LDEC Permit - Minor.....	29
12.2	LDEC Permit - Major	30
12.3	Fee.....	32
12.4	LDEC Permit Authorization	32
12.5	LDEC Permit Duration	33
12.6	Responsibility of the Permittee.....	33
12.7	Required Maintenance During and After Construction	33
13.	ADMINISTRATION OF LDEC PERMITS.....	34
13.1	Zoning Administrator.....	34
13.2	Conditions of Approval.....	34
13.3	LDEC Permit Denial.....	34
13.4	Changes to LDEC Permits and Plans.....	34
13.5	Required Inspection.....	35
14.	LIABILITY RELATED TO LDEC PERMITS.....	36
15.	ENFORCEMENT OF LDEC PERMITS.....	36
15.1	Compliance.....	36
15.2	Deficiency.....	36
15.3	Non-Compliance.....	36
15.4	Notice of Violation	36
15.5	Prevention of Hazard.....	37
15.6	Stop-Work Order.....	37
15.7	Legal Proceedings.....	38

Champaign County, Illinois
Storm Water Management and Erosion Control Ordinance

15.8	Penalties	38
16.	RULES OF CONSTRUCTION	39
17.	APPEAL, WAIVER OR VARIANCE	39
18.	EFFECTIVE DATE	39
	Appendix A: Adopting Resolution and Amendments	A-1
	Appendix B: Exempt Impervious Area	B-1
	Appendix C: Champaign County MS4 Jurisdictional Area	C- 1
	Appendix D: Technical Manual Minor Land Disturbance Erosion Control Permit	D-1
	Appendix E: Technical Manual Major Land Disturbance Erosion Control Permit.....	E-1
	Appendix F: Standard Details	F-1

Champaign County, Illinois
Storm Water Management and Erosion Control Ordinance

1.0 AUTHORITY

1.1 Title

This Ordinance shall be known, and may be cited as, the Champaign County Storm Water Management and Erosion Control Ordinance.

1.2 Illinois Compiled Statutes

This Ordinance has been adopted pursuant to Champaign County's authority to zone land (55 ILCS 5/5-12001); Champaign County's authority to adopt rules and regulations for subdivisions (55 ILCS 5/5-1041); and Champaign County's authority to prevent water pollution (55 ILCS 5/5-15015); Champaign County's authority to establish and implement a comprehensive and coordinated erosion and sediment control plan in cooperation with other units of government (70 ILCS 405/3.12); and other applicable authority, all as amended from time to time.

2. PURPOSE

The purpose of this ordinance is to accomplish the following:

- A. Protect the existing agricultural and natural drainage infrastructure.
- B. Provide for adequate drainage of DEVELOPMENT SITES and surrounding areas.
- C. Guide DEVELOPERS' and builders' attempts to control the movement of STORM WATER and reduce damage to property.
- D. Conserve, preserve and enhance the natural resources of the County, including its SOILS, waters, vegetation, fish and wildlife.
- E. Promote public welfare and protect waters under the Clean Water Act by guiding, regulating and controlling the design, CONSTRUCTION, use and maintenance of any DEVELOPMENT or other activity that disturbs SOIL on land situated within the County.
- F. Safeguard persons and protect property from the hazards and negative impacts of SOIL EROSION created by LAND DISTURBANCE.
- G. Prevent flooding caused by silt clogging STORM WATER management infrastructure, such as STORM SEWERS, inlets and receiving CHANNELS or streams.
- H. Control the rate of release of STORM WATER and require temporary storage of STORM WATER from DEVELOPMENT SITES.
- I. Preserve and enhance water quality by preventing silt-laden water from reaching creeks, CHANNELS, streams, WETLANDS and other public waterways.
- J. Fulfill the applicable requirements of the NPDES Phase II Storm Water permit.

3. DEFINITIONS

The following definitions shall apply to this Ordinance. Words not defined in this Section shall be interpreted in accordance with the definitions contained in Webster's New Collegiate Dictionary.

AGRICULTURE: The growing, harvesting and storing of crops including legumes, hay, grain, fruit and truck or vegetable crops, floriculture, horticulture, mushroom growing, orchards, forestry, and the keeping, raising, and feeding of livestock or poultry, including dairying, poultry, swine, sheep, beef cattle, pony and horse production, fur farms, and fish and wildlife farms; farm

Champaign County, Illinois
Storm Water Management and Erosion Control Ordinance

BUILDINGS used for growing, harvesting, and preparing crop products for market, or for use on the farm; roadside stands, farm **BUILDINGS** for storing and protecting farm machinery and equipment from the elements, for housing livestock or poultry and for preparing livestock or poultry products for market; farm **DWELLINGS** occupied by farm **OWNERS**, operators, tenants or seasonal or year-round hired farm workers. It is intended by this definition to include within the definition of **AGRICULTURE** all types of agricultural operations, but to exclude therefrom industrial operations such as a grain elevator, canning, or slaughterhouse, wherein agricultural products produced primarily by others are stored or processed. Agricultural purposes include, without limitation, the growing, developing, processing, conditioning, or selling of hybrid seed corn, seed beans, seed oats, or other farm seeds.

APPLICANT: The legal entity who submits an application to the County for a **LDEC PERMIT** pursuant to this ordinance.

BEST MANAGEMENT PRACTICES (BMPs): A technique or series of techniques which are proven to be effective in controlling **STORM WATER**, **EROSION**, and **SEDIMENTATION**.

BORROW: The earth material acquired from an off-site location for use in **GRADING** on a site.

CERTIFIED PROFESSIONAL IN EROSION AND SEDIMENT CONTROL: An individual with **CPESC** Certification.

CHANNEL: A natural or artificial water course of perceptible extent which periodically or continuously contains moving water, or which forms a connecting line between two (2) bodies of water. It has a definite bed and banks which serve to confine water.

CLEARING AND GRUBBING: The cutting and removal of trees, shrubs, bushes, windfalls and other vegetation including removal of stumps, roots, and other remains in the designated areas.

COMMON PLAN OF DEVELOPMENT OR SALE OF RECORD: All or part of a parcel of land that existed on {effective date} where multiple separate and distinct **CONSTRUCTION** activities may be taking place at different times on different schedules, and possibly (not necessarily) under different ownership. Examples include: 1) phased projects and projects with multiple filings or lots, even if the separate phases or filings/lots will be constructed under separate contract or by separate **OWNERS** (e.g., a **DEVELOPMENT** where lots are sold to separate builders); 2) a **DEVELOPMENT** plan that may be phased over multiple years but is still under a consistent plan for long-term **DEVELOPMENT**; and 3) projects in a contiguous area that may be unrelated but still under the same contract, such as **CONSTRUCTION** of a building extension and a new parking lot at the same facility and any **DEVELOPMENT** or **CONSTRUCTION** under a Rural Residential Overlay District; 4) a Plat of Subdivision of two or more lots; 5) A Plat of Survey of two or more lots; 6) A diagram of two or more lots presented in a real estate marketing brochure or advertisement. A long range **DEVELOPMENT** plan that is conceptual (rather than a specific plan of future **DEVELOPMENT** and the future construction activities would happen over an extended time period) will be considered as having separate **DEVELOPMENT** plans, provided that the periods of construction for the physically interconnected phases will not overlap. The disturbed area of the entire plan shall be used in determining **LDEC PERMIT** requirements. **DEVELOPMENT** on by-right lots created from any single parcel that existed on 1/1/2009 in the AG-1, AG-2 and CR Districts is not included under this definition unless the lots are created by a Plat of Subdivision or Plat of Survey or marketed by means of a brochure or advertisement.

Champaign County, Illinois
Storm Water Management and Erosion Control Ordinance

CONSTRUCTION: The excavation of earth to provide for a foundation, basement or cellar; and/or, the addition to or removal from a LOT or tract of land of earth or water so as to prepare said LOT or tract of land for the CONSTRUCTION of a STRUCTURE: and/or, the act of placing or affixing a component of a STRUCTURE upon the ground or upon another such component; and/or, the placing of CONSTRUCTION materials in a permanent position and fastening in a permanent manner; and /or, the DEMOLITION, elimination, and./ or removal of an existing STRUCTURE in connection with such CONSTRUCTION and/or the CONSTRUCTION or placement of STORM WATER MANAGEMENT facilities or EROSION control BMPs.

CONTIGUOUS URBAN GROWTH AREA (CUGA): Areas outside of municipal limits and within municipal one and one-half mile extraterritorial jurisdiction destined for urban type land uses.

CONTRACTOR: The person who contracts with the PERMITTEE, OWNER, DEVELOPER, or another CONTRACTOR (subcontractor) to undertake any or all the land disturbing activities covered by this Ordinance.

CONTRACTOR'S CERTIFICATION STATEMENT: A document required by the IEPA as part of the ILR10 construction site activity permit.

CONTROL STRUCTURE: A facility constructed to regulate the volume and rate of storm water that is released during a specific length of time.

CULVERT: A closed conduit for the passage of surface drainage water under a roadway, railroad or other surface impediment.

DEMOLITION: Any act or process of wrecking or destroying a building or STRUCTURE.

DEMOLITION PERMIT: A permit for DEMOLITION activities that are planned for areas outside of the MS4 JURISDICTIONAL AREA.

DETENTION BASIN: A temporary or permanent natural or manmade STRUCTURE that provides for the temporary storage of STORM WATER.

DETENTION STORAGE: Temporary detention or storage of storm water in storage basins, on rooftops, in parking lots, school yards, parks, open space, lakes, ponds, or other areas under predetermined and controlled conditions, with the rate of drainage therefrom regulated by appropriately installed devices.

DEVELOPER: Any person, firm, corporation, sole proprietorship, partnership or political subdivision engaged in a LAND DISTURBANCE activity.

DEVELOPMENT: Any man-made change to improved or unimproved real estate including but not limited to, construction of or substantial improvements to buildings or other structures, the placement of mobile homes, paving, mining, filling or other similar activities.

DISCHARGE: The rate of outflow of water from a storm water drainage or storm water detention facility.

Champaign County, Illinois
Storm Water Management and Erosion Control Ordinance

DRY BOTTOM STORM WATER DETENTION BASIN: A facility that is designed to be normally dry and which accumulates storm water runoff only during periods when the restricted storm water runoff release rate is less than the storm water inflow rate.

EROSION: The wearing away of the ground surface as a result of the movement of wind, water, ice, and/or LAND DISTURBANCE activities.

EROSION AND SEDIMENT CONTROL PLAN (ESCP): A plan which includes a set of BMPs or equivalent measures designed to control STORM WATER and EROSION and to retain SEDIMENT on a particular SITE during the period in which pre-CONSTRUCTION and CONSTRUCTION-related land disturbances, fills, and soil storage occur, and before final improvements are completed, all in accordance with the specific requirements established in section entitled Land Disturbance Erosion Control (Section 11) in this Ordinance.

EROSION CONTROL: Any measures taken to temporarily or permanently prevent or manage EROSION in a way that minimizes undesirable impacts.

EROSION CONTROL INSPECTOR: The ZONING ADMINISTRATOR or representative who has the authority to inspect SITES for compliance with the standards set forth in this Ordinance.

EROSION CONTROL INSPECTION REPORT (ECIR): The compliance report as defined by the Illinois Environmental Protection Agency in the General NPDES permit ILR10.

EXCAVATION: The mechanical removal of earth material.

FILL: A deposit of SOIL or other earth materials placed by artificial means.

FINAL EROSION AND SEDIMENT CONTROL PLAN (FINAL ESCP): A plan which includes permanent measures and BEST MANAGEMENT PRACTICES to control STORM WATER and control SEDIMENT if such permanent measures are not included in the ESCP.

FINAL STABILIZATION: All soil disturbing activities at the site have been completed and either of the two following conditions are met: 1) A uniform (e.g., evenly distributed, without large bare areas) perennial vegetative cover with a density of 70 percent of the native background vegetative cover for the area has been established on all unpaved areas and areas not covered by permanent structures, or 2) Equivalent permanent stabilization measures (such as the use of riprap, gabions, or geotextiles) have been employed. For individual LOTS in residential CONSTRUCTION, FINAL STABILIZATION means that either 1) The homebuilder has completed FINAL STABILIZATION as specified above, or 2) The homebuilder has established temporary stabilization including perimeter controls for an individual lot prior to occupation of the home by the homeowner and informing the homeowner of the need for, and benefits of, FINAL STABILIZATION.

FLOODPLAIN: The area adjoining a WATERCOURSE which could be inundated by a flood that has a one (1) percent chance of being equaled or exceeded in any given year and is delineated on Federal Emergency Management Agency Flood Insurance Rate Maps (FIRM).

GRADE: The vertical elevation of the ground surface.
(a) Existing grade is the grade prior to GRADING.

Champaign County, Illinois
Storm Water Management and Erosion Control Ordinance

- (b) Rough grade is the stage at which the grade approximately conforms to the approved plan.
- (c) Finish grade is the final grade of the SITE which conforms to the approved process.

GRADING: EXCAVATION or FILL or any combination thereof.

GRADING PERMIT: A permit for GRADING activities that are planned for areas outside of the MS4 JURISDICTIONAL AREA.

ILLINOIS ENVIRONMENTAL PROTECTION AGENCY (IEPA): The Illinois Environmental Protection Agency.

ILLINOIS URBAN MANUAL: This term shall mean “A Technical Manual designed for Urban Ecosystem Protection and Enhancement”, prepared by the United States Department of Agriculture (USDA) Natural Resources Conservation Service.

ILR10: The Illinois Environmental Protection Agency's general National Pollutant Discharge Elimination System (NPDES) Construction Storm Water Permit covering anyone conducting a land disturbing activity which disturbs one (1) or more acres of total land area or a construction SITE less than one acre of total land that is a part of a COMMON PLAN OF DEVELOPMENT OR SALE OF RECORD if the larger common plan will ultimately disturb one or more acres total land area.

IMPERVIOUS: A term applied to materials through which water cannot pass, or through which water passes with great difficulty or at a very slow rate.

INCIDENCE OF NON-COMPLIANCE (ION): A report to the IEPA providing information about the cause of the non-compliance and description of the measures taken to prevent further non-compliances with the ILR10 permit.

LAND DISTURBANCE: Any land change that may result in SOIL EROSION from wind, water and/or ice and the movement of SEDIMENT unto or upon waters, lands, or rights-of-way within the County, including but not limited to DEMOLITION, CLEARING AND GRUBBING, GRADING, excavating, transporting and filling of land. LAND DISTURBANCE is not limited to a single instance of LAND DISTURBANCE, but is the total LAND DISTURBANCE that has occurred or may reasonably be expected to occur to any part of a given tract of land. LAND DISTURBANCE does not include the following:

- (a) AGRICULTURE.
- (b) Land disturbance activities including, but not limited to, underground utility repairs, home gardens, minor repairs.
- (c) Installation of fence, sign, telephone, and electric poles and other kinds of posts or poles.
- (d) Emergency work to protect life, limb, or property and emergency repairs. If the emergency land disturbing activity would have required and approved ESCP, then the land area disturbed shall be shaped and stabilized in accordance with the requirements of this Ordinance.

LAND DISTURBANCE EROSION CONTROL PERMIT (LDEC PERMIT): Includes both LAND DISTURBANCE EROSION CONTROL PERMIT – MAJOR and LAND DISTURBANCE EROSION CONTROL PERMIT – MINOR as defined in this Ordinance and issued by the County Zoning Administrator pursuant to this Ordinance.

Champaign County, Illinois
Storm Water Management and Erosion Control Ordinance

LAND DISTURBANCE EROSION CONTROL PERMIT – MAJOR: A class of the LDEC PERMIT required where 1 acre or more of land will be disturbed.

LAND DISTURBANCE EROSION CONTROL PERMIT – MINOR: A class of LDEC PERMIT required where less than one acre of land that is part of a COMMON PLAN OF DEVELOPMENT OR SALE OF RECORD will be disturbed.

LETTER OF NOTIFICATION: A letter from the IEPA stating that the PERMITTEE has the authority to construct.

LETTER OF TERMINATION: A document required by Champaign County as part of the Land Disturbance Erosion Control and Storm Water Management Ordinance. This document notifies the ZONING ADMINISTRATOR of the request to end coverage for CONSTRUCTION under the terms of the ILR10 permit when no STORM WATER DRAINAGE PLAN is required. This is submitted to the Zoning Administrator.

LOT: A designated parcel, tract or area of land established by plat, SUBDIVISION or as otherwise permitted by law, to be used, developed or built upon as a unit.

MS4 JURISDICTIONAL AREA: The limits of the Urbanized Area as defined by the Bureau of the Census.

NON-STRUCTURAL CONTROLS: Institutional and pollution prevention type practices through education and source control, recycling, and maintenance that prevent pollutants from entering STORM WATER or reduce the amount of RUNOFF requiring management.

NOTICE OF INTENT (NOI): A document required by the IEPA as part of the ILR10 construction SITE activity permit. This document is the application for an ILR10 construction SITE activity permit from the IEPA.

NOTICE OF TERMINATION (NOT): A document required by the IEPA as part of the ILR10 construction SITE activity permit. This document requests the end of coverage for CONSTRUCTION under the terms of the ILR10 permit.

OWNER: Any person with a legal or equitable interest in the land for which a LDEC PERMIT has been issued.

PERMITTEE: The APPLICANT in whose name a valid LDEC PERMIT is duly issued pursuant to this Ordinance and his/her agents, employees, and others, acting under his/her direction.

PROFESSIONAL ENGINEER: A person licensed under the laws of the State of Illinois to practice professional engineering.

PROJECT TERMINATION: Specific activities required to occur to release the requirements of the Land Disturbance Erosion Control Permit or to complete the requirements for a Zoning Compliance Certificate or to complete the construction of improvements pursuant to approval of a Final Plat of Subdivision.

Champaign County, Illinois
Storm Water Management and Erosion Control Ordinance

RETURN PERIOD: The average interval of time within which a given rainfall event will be equaled or exceeded once. A flood having a return period of 50 years has a two (2) percent probability of being equaled or exceeded in any one (1) year.

RUNOFF: Volumes and / or velocities associated with precipitation amounts and/or intensities during periodic storm events.

SEDIMENT: Soils or other surficial materials transported by SURFACE WATER as a product of EROSION.

SEDIMENTATION: The process or action of depositing SEDIMENT that is determined to have been caused by EROSION.

SITE: The entire area of land on which the LAND DISTURBANCE activity is proposed in the LDEC PERMIT application.

SITE PLAN: A plan or set of plans showing the details of any LAND DISTURBANCE activity of a SITE including, but not limited to, the CONSTRUCTION of: STRUCTURES, open and enclosed drainage facilities, STORM WATER MANAGEMENT facilities, parking lots, driveways, curbs, pavements, sidewalks, bike paths, recreational facilities, ground covers, plantings, and landscaping.

SLOPE: The incline of a ground surface expressed as a ratio of horizontal distance to vertical distance.

SOIL: Naturally occurring surface deposits overlying bedrock.

STOP-WORK ORDER: A document issued by the Zoning Administrator that directs work to stop on a CONSTRUCTION SITE if LAND DISTURBANCE activities are in violation of this Ordinance.

STORM SEWER: A closed conduit for conveying collected storm water runoff.

STORM WATER: Rain RUNOFF, snow melt RUNOFF, surface RUNOFF and drainage.

STORM WATER DRAINAGE PLAN: A written document in conformance with the requirements of Section 9 of this ordinance.

STORM WATER DRAINAGE SYSTEM: All means, natural or man-made, used for conducting storm water runoff to, through or from a drainage area to the point of final outlet including but not limited to any of the following: conduits, STORM SEWERS, swales, canals, CHANNELS, ditches, streams, CULVERTS, streets, and pumping stations.

STORM WATER MANAGEMENT: Any measure taken to permanently reduce or minimize the negative impacts of RUNOFF.

STORM WATER POLLUTION PREVENTION PLAN (SWPPP): A document required by the IEPA as part of the ILR10 construction SITE activity permit. This document is a written description of the erosion and sediment control plan for a CONSTRUCTION SITE.

Champaign County, Illinois
Storm Water Management and Erosion Control Ordinance

STORM WATER STORAGE AREA: An area designated to accumulate excess storm water runoff.

STRIPPING: Any activity which removes or significantly disturbs the vegetative surface cover including clearing, grubbing of stumps and root mat, and topsoil removal.

STRUCTURAL CONTROLS: Practices to divert flows from exposed SOILS, store flows or otherwise limit RUNOFF and the movement of pollutants from exposed areas of a CONSTRUCTION SITE.

STRUCTURE: Anything manufactured, constructed or erected which is normally attached to or positioned on land, including buildings, portable or earthen constructs, roads, parking lots, and paved storage areas.

SUBDIVISION: Any division, DEVELOPMENT, or re-subdivision of any part, LOT, area or tract of land by the OWNER or agent, either by LOTS or by metes and bounds into LOTS two or more in number, for the purpose, whether immediate or future, of conveyance, transfer, improvement, or sale with the appurtenant streets, alleys, and easements, dedicated or intended to be dedicated to public use or for the use of the purchasers or OWNERS within the tract subdivided. The division of land for AGRICULTURAL purposes not involving any new street, alley, or other means of access shall not fall under this definition for the purpose of the regulations and standards of this ordinance.

SURFACE WATER: Waters upon the surface of the earth in bounds created naturally or artificially including, but not limited to, streams, other water courses, lakes and reservoirs.

SURVEYOR: A person duly registered or authorized to practice land surveying in the State of Illinois.

TIME OF CONCENTRATION: The time required for storm water runoff from the most remote part of the drainage basin to reach the point being considered. Minimum time of concentration required for design of drainage facilities shall be 15 minutes.

TOPSOIL: The upper layer of SOIL.

TRIBUTARY WATERSHED: The entire catchment area that contributes storm water runoff to a given point.

USE: The specific purpose for which land is designed arranged, intended, or for which it is or may be occupied or maintained. This shall not include any nonconforming use.

WASHOUT FACILITY: A location where CONSTRUCTION waste such as concrete, asphalt or similar material can be temporarily stored until final disposal of the material. WASHOUT FACILITIES shall be designated by the LDEC PERMIT holder before work begins and shall be located in an appropriate area where the waste resulting from the washout cannot enter sewer systems or local waterways. Waste from the WASHOUT FACILITIES shall be disposed of in an approved manner according to state laws.

Champaign County, Illinois
Storm Water Management and Erosion Control Ordinance

WATERCOURSE: Any natural or improved stream, river, creek, ditch, CHANNEL, canal, conduit, gutter, CULVERT, drain, gully, swale, or wash in which waters flow either continuously or intermittently.

WATERSHED: A region draining to a specific river, river system, or body of water.

WET BOTTOM STORM WATER STORAGE AREA: A facility that contains a perpetual body of water and which accumulates excess storm water during periods when the restricted storm water runoff release rate is less than the storm water runoff inflow rate.

WETLANDS: A lowland area such as a marsh, that is saturated with moisture, as defined in Section 404, Federal Water Pollution Control Act Amendments of 1987.

ZONING ADMINISTRATOR: The county personnel provided for in the Zoning Ordinance and who has the authority and duty to administer adopted ordinances including the Erosion and Sediment Control Ordinance.

ZONING DISTRICT: As provided for in the Zoning Ordinance, a section of the County/City/Village in which zoning regulations and standards are uniform.

4. SCOPE

4.0 Applicability

The IEPA ILR10 and/or this Ordinance apply to LAND DISTURBANCE, SUBDIVISION and/or CONSTRUCTION as indicated below:

- A. All requirements of the IEPA ILR10 permit apply as follows:
 1. ILR10 requirements apply when LAND DISTURBANCE activities disturb one acre or greater or less than an acre if it is part of a COMMON PLAN OF DEVELOPMENT OR SALE OF RECORD that ultimately disturbs one acre or greater, ILR10 requirements apply to individual LOTS when those LOTS are created as part of a COMMON PLAN OF DEVELOPMENT OR SALE OF RECORD and LAND DISTURBANCE occurs on one acre or more. When a COMMON PLAN OF DEVELOPMENT OR SALE OF RECORD is under FINAL STABILIZATION, subsequent LAND DISTURBANCE of individual lots are required to obtain an ILR10, if the combination of LAND DISTURBANCE on individual lots could result in one acre or more LAND DISTURBANCE at one time.
 2. When a LOT is converted from agricultural use to other land use, the land shall be vegetated with an appropriate protective land cover prior to any application for a Zoning Use Permit or Subdivision Approval or else the land shall be considered to be in a state of land disturbance and subject to ILR10 requirements unless documentation from the Illinois Environmental Protection Agency or the US Environmental Protection Agency indicates otherwise.

3. The ZONING ADMINISTRATOR shall notify all Applicants when ILR10 requirements appear to be applicable.
 4. Copies of the ILR10 NOTICE OF INTENT and ILR10 NOTICE OF TERMINATION must be submitted to the ZONING ADMINISTRATOR to demonstrate compliance with ILR10 requirements when LAND DISTURBANCE activities disturb one acre or greater, or less than an acre if it is part of a COMMON PLAN OF DEVELOPMENT OR SALE OF RECORD that ultimately disturbs one acre or greater, pursuant to the following:
 - a. Any Major LDEC Permit as authorized under Section 12.3.
 - b. Any Floodplain Development Permit as authorized by the Champaign County Special Flood Hazard Area Ordinance.
- B. Within the Champaign County MS4 JURISDICTIONAL AREA (see Appendix C), all Sections of this Ordinance may apply subject to relevant exemptions.
- C. Outside of the Champaign County MS4 JURISDICTIONAL AREA (see Appendix C), all Sections of this Ordinance may apply subject to relevant exemptions, except those sections relevant only to Land Disturbance Erosion Control Permits (Section 12, 13, 14, and 15).

4.1 General Exemptions

The following activities are exempt from this Ordinance.

- A. AGRICULTURE
- B. Emergencies posing an immediate danger to life or property, or substantial flood or fire hazards.
- C. Digging activities related to cemetery grave sites.
- D. LAND DISTURBANCE on LOTS subject to municipal annexation agreements.
- E. LAND DISTURBANCE pursuant to a statewide or regional permit administered by the Illinois Department of Natural Resources Office of Water Resources (IDNR/OWR) and provided that information sufficient to document compliance with the relevant statewide or regional permit is submitted to the ZONING ADMINISTRATOR at least one week prior to the start of LAND DISTURBANCE. This exemption is only applicable to that portion of CONSTRUCTION or LAND DISTURBANCE that is eligible for the statewide or regional permit.
- F. LAND DISTURBANCE activities by or for a recognized Drainage District.
- G. Any LAND DISTURBANCE occurring either in a public street right-of-way or a railroad right-of-way, that is done by or for either the unit of government that has maintenance authority of that street right-of-way or for any utility that is authorized to use any portion of the public street right-of-way or the railroad that has the use of that railroad right-of-way.

4.2 Storm Water Drainage Plan Exemptions

All SUBDIVISIONS or CONSTRUCTION meeting any of the following conditions are exempt from the STORM WATER DRAINAGE PLAN (Section 9) requirements:

- A. All General Exemptions (Section 4.2).
- B. CONSTRUCTION on lots in subdivisions or other DEVELOPMENTS that are subject to municipal subdivision regulations containing standards for the detention and controlled release of storm water, for provision of adequate site drainage, and for the protection of existing drainage facilities or on lots subject to the application of such standards by means of an annexation agreement.
- C. CONSTRUCTION of additions to existing STRUCTURES when the total increase in IMPERVIOUS area is less than 10,000 square feet relative to the impervious area that existed on February 20, 2003;
- D. CONSTRUCTION located on a lot no more than one acre in area that existed on December 17, 1991.
- E. Individual single family and two-family detached dwellings and related accessory STRUCTURES on a single lot.
- F. SUBDIVISIONS or CONSTRUCTION on lots when the cumulative total of all IMPERVIOUS areas from all developed lots created from a lot or lots in common ownership on January 1, 1998, including any specific IMPERVIOUS area addition to the adjacent public streets that is required to accommodate the SUBDIVISION or CONSTRUCTION, is less than the criteria shown in Table 1 - Maximum Exempt Impervious Area:

Table 1 - Maximum Exempt Impervious Area

Lot area*	Maximum exempt impervious area*
a. No more than .25 acre	Up to 100% of the lot may be impervious area
b. More than .25 acre but less than 2.0 acres	The limit on percent impervious area declines from 100% to 50% of the total lot or lots area plus 0.14 acres. See the graph of Exempt Impervious Area (Appendix B) or use the Mathematical Expressions on the graph to determine the limit for impervious area on a specific lot size.
c. More than 2.0 acres but not more than 6.25 acres	No more than 1 acre of the lot or lots shall be impervious surface area
d. More than 6.25 acres	No more than 16% of the total area of the lot or lots shall be impervious area provided that no exemption shall apply to any part of a lot when that part contains more than one acre of impervious surface area within a rectangular area of 90,000 square feet with a minimum dimension of 150 feet.

* "Lot area" refers to a single lot and to the cumulative total area of lot or lots that are created out of a larger tract. See paragraph 4.3F. for other rules of application for exemptions.

- G. The following rules govern the application of the Storm Water Drainage Plan Exemptions (Section 4.3), but shall not affect how the IMPERVIOUS area is calculated or determined for engineering design purposes.

1. Measurement of the total area and IMPERVIOUS area of a LOT or SUBDIVISION is based on the entire area designated by the legal description of the tract for which the approval is requested, together with that of other contiguous LOTS, when required pursuant to Section 4.3F4. except for the area of adjacent public street right-of-ways as required by Section 4.3F.2.c.
2. Measurement of the total area and IMPERVIOUS area shall exclude the following:
 - a. Portions of the LOT or LOTS that are devoted to cropland and that will remain devoted to cropland; and
 - b. Portions of public street right-of-ways adjacent to any such areas of cropland.
 - c. Portions of public street right-of-ways not containing any specific IMPERVIOUS area addition to the adjacent public streets that is required to accommodate the SUBDIVISION or construction. When specific additions of public street IMPERVIOUS area are required to accommodate a specific SUBDIVISION or construction, the specific addition of public street IMPERVIOUS area shall not be excluded.
3. Areas that are comprised of a permanent vegetative cover that is generally at least equivalent to "Poor condition (grass cover less than 50 percent)" using the TR-55 Design Method shall not be considered IMPERVIOUS.
4. IMPERVIOUS area limits and exemptions shall be applied separately for different portions of the lot or SUBDIVISION in the following instances:
 - a. For each portion of the lot or SUBDIVISION that drains to a common point on the boundary of the total SITE (drainage sub-basin).
 - b. For each portion of the lot or SUBDIVISION that drains to a drainage way that serves upstream areas that are under different ownership and that divides that portion of the lot or SUBDIVISIONS from the remainder of the lot or SUBDIVISIONS.
5. Pursuant to Section 4.3E., LOTS shall be considered as developed when the LOT or LOTS are:
 - a. Occupied by other than farm structures; or
 - b. Covered in whole or in part by any IMPERVIOUS area except for driveways or parking areas used for agricultural purposes and existing public streets; or
 - c. Included in a plat or legal description and marketed for sale.

4.3 LDEC Permit Exemptions

All LAND DISTURBANCE activities located completely or partially within the MS4 Jurisdictional Area and meeting any of the following conditions are exempt from the LAND DISTURBANCE EROSION CONTROL PERMIT requirements (Section 12, 13, 14 and 15) in this Ordinance:

- A. All General Exemptions (Section 4.2)
- B. LAND DISTURBANCE of less than one acre but greater than 10,000 square feet of land on all or part of a parcel of land that existed on {effective date} provided that the land is not part of any of the following:
 1. A COMMON PLAN OF DEVELOPMENT OR SALE OF RECORD where 1 acre or greater area of LAND DISTURBANCE could occur; or
 2. In a Residential, Business, or Industrial ZONING DISTRICT as established in the Zoning Ordinance and indicated on the Zoning Map; or
 3. In an existing subdivision of more than four LOTS including any subsequent replat in the AG-1, AG-2, or CR ZONING DISTRICT as defined in the Zoning Ordinance.
- C. LAND DISTURBANCE less than 10,000 square feet in area.

4.5 GRADING and DEMOLITION PERMIT Exemptions

All GRADING and DEMOLITION meeting the following conditions are exempt from the requirement for a GRADING PERMIT and/or a DEMOLITION PERMIT:

- A. Any GRADING or DEMOLITION pursuant to any of the exempted activities listed in Section 4.2.
- B. GRADING and/or DEMOLITION that is not part of or related to other CONSTRUCTION and that will result in less than one acre of LAND DISTURBANCE and that is not part of a larger COMMON PLAN OF DEVELOPMENT OR SALE OF RECORD.
- C. GRADING and/or DEMOLITION that is related to and authorized in a ZONING USE PERMIT or a Floodplain Development Permit or a LDEC PERMIT.

5. AUTHORIZATIONS AND PROJECT TERMINATION

5.0 Approval Authorities

For the purposes of this Ordinance the Approval Authorities are as follows:

- A. For all SUBDIVISIONS, the Environment and Land Use Committee of the Champaign County Board.
- B. For Zoning Use Permits, Easements, as-built drawings, STORM WATER DRAINAGE PLANS and LDEC PERMITS the Champaign County Zoning Administrator.

5.1 Authorizations

Authorization for any LAND DISTURBANCE activity shall include the following acts in order:

- A. Approval of the STORM WATER DRAINAGE PLAN if required by STORM WATER DRAINAGE PLAN (Section 9) in this Ordinance; and
- B. The APPLICANT or other necessary party files with the Champaign County Recorder of Deeds any required easement or other legal instrument that is needed to implement or maintain the STORM WATER DRAINAGE PLAN, except for a Final Plat of SUBDIVISION, Owner's Certificate, or private SUBDIVISION covenants, and except as provided for in Easements (Section 7); and
- C. Approval of Engineering Drawings required for any Plat of Subdivision, if applicable including the extent and nature of all proposed LAND DISTURBANCE; and
- D. For LAND DISTURBANCES in the MS4 JURISDICTIONAL AREA, approval of a LDEC PERMIT if required by LDEC Permits (Section 12) and written approval of the inspection required in Required Inspections (Section 13.5); or
- E. For LAND DISTURBANCES outside of the MS4 JURISDICTIONAL AREA that total an acre or more of LAND DISTURBANCE or less than an acre when part of a larger COMMON PLAN OF DEVELOPMENT OR SALE OF RECORD that will result in an acre or more of LAND DISTURBANCE, a copy of any required NOTICE OF INTENT pursuant to Section 4.1A. of this Ordinance or a copy of a statement from IEPA that there is no ILR10 requirement; and
- F. Approval of a Zoning Use Permit, if required by the Zoning Ordinance, including the extent and nature of all proposed LAND DISTURBANCE.
- G. Approval of any required GRADING PERMIT or DEMOLITION PERMIT outside of the MS4 JURISDICTIONAL AREA.

5.2 Project Termination

PROJECT TERMINATION shall include the following acts:

- A. Any required as-built drawings or other documentation has been accepted by the Approval Authority as evidence that the requirements in Certifications (Section 9.6) have been met; and
- B. The APPLICANT or other necessary party files any required easement or other legal instrument with the Champaign County Recorder of Deeds, needed to implement the requirements in Easements (Section 7), except for a Final Plat of Subdivision, Owner's Certificate, or private subdivision covenants; and
- C. The following acts related to CONSTRUCTION related to any Final Plat of Subdivision, if applicable:
 - 1. Approval of a Final Plat of SUBDIVISION after the CONSTRUCTION of all required physical improvements required by the SUBDIVISION Regulations, and
 - 2. Full and complete release of any Performance Guarantee related to any Final Plat of SUBDIVISION; and
- D. Acceptance by the ZONING ADMINISTRATOR of the certifications required in Certifications (Section 9.6) if applicable; and
- E. Full approval and unconditional issuance of a Zoning Compliance Certificate, if required by the Zoning Ordinance; and
- F. For projects within the MS4 JURISDICTIONAL AREA, if a LDEC PERMIT is required by LDEC Permits (Section 12), a NOTICE OF TERMINATION shall be submitted to the IEPA and/ or the ZONING ADMINISTRATOR, whichever is applicable; or
- G. For projects outside of the MS4 JURISDICTIONAL AREA, a copy of any required Notice of Termination if required by ILR10 pursuant to paragraph 4.1A.4. of this Ordinance.

6. PROTECT EXISTING DRAINAGE AND WATER RESOURCES

6.1 General Requirement

- A. No FILL shall be placed nor GRADE altered in such a manner that it will cause SURFACE WATER upstream of the DEVELOPMENT to pond or direct surface flows in such a way as to create a nuisance.
- B. All STORM WATER shall exit the DEVELOPMENT at non-erosive velocities. All subsurface flows shall exit the DEVELOPMENT at such a velocity so as to prevent an increase in scouring or structural damage to off-site tile drains.
- C. Sizing of CULVERT crossings shall consider entrance and exit losses as well as tail water conditions on the CULVERT.
- D. No sump pump discharge or discharge from any private wastewater treatment system from a principal use established after {effective date} shall discharge directly into or within 25 feet of a roadside ditch, off-site drainage swale, stream, property line, or in such a way that it creates a nuisance condition at any time of the year or contributes to erosion.
- E. No sump pump discharge or STORM WATER shall be directed to any sanitary sewer.

- F. The requirements in Land Disturbance Erosion Control (Section 11) in this Ordinance notwithstanding, CONSTRUCTION or LAND DISTURBANCE shall minimize EROSION on any property and minimize SEDIMENT deposited on any adjacent property or any adjacent street or adjacent drainage ditch, roadside ditch, or stream.

6.2 Natural Drainage

- A. Existing perennial streams shall not be modified to accommodate RUNOFF. Stream banks may be modified, however, incident to the installation of excess RUNOFF outfalls, necessary to ensure safety or bank stabilization, and/or for the improvement of aquatic habitats, and subject to any required local, state, and federal permits.
- B. Other natural drainage features such as depressional storage areas and swales shall be incorporated into the STORM WATER DRAINAGE SYSTEM.
- C. Surface water shall be allowed to travel its existing or natural course unless changes are allowed by means of a duly approved STORM WATER DRAINAGE PLAN.
- D. It shall be unlawful for any person to cause or maintain any obstruction within a WATERCOURSE or any part of the drainage system, except as may be specifically authorized by a duly approved STORM WATER DRAINAGE PLAN.

6.3 Agricultural and Other Drainage Improvements

- A. The outlet for existing agricultural drainage tile will be located and the capacity of the outlet shall be maintained for the WATERSHED upstream of the DEVELOPMENT area.
- B. Existing easements for any agricultural drainage tile located underneath areas that will be developed shall be preserved. If no easement exists an easement shall be granted for access and maintenance as provided in Easements (Section 7). Such easements shall be of sufficient width and located to provide for continued functioning and necessary maintenance of drainage facilities. No buildings or permanent STRUCTURES including paved areas but excluding streets, sidewalks, or driveways, which cross the easement by the shortest possible route may be located within the easement without the consent and approval of any public body to which the easement is granted.
- C. All agricultural drainage tile located underneath areas that will be developed shall be replaced with non-perforated conduit to prevent root blockage provided however that drainage district tile may remain with the approval of the drainage district.
- D. Agricultural drainage tile which, due to DEVELOPMENT, will be located underneath roadways, drives, or parking areas as allowed by Paragraph C above shall be replaced with ductile iron, or reinforced concrete pipe or equivalent material approved by the Approval Authority as needed to prevent the collapse of the agricultural drainage conduit.
- E. Agricultural drainage tile may be relocated within DEVELOPMENT areas upon approval of the Approval Authority. Such relocation shall maintain sufficient SLOPE and capacity to prevent SEDIMENTATION and to prevent an increase in scouring or structural damage to the conduit. Such relocation shall only be with the consent and approval of the drainage district which is responsible for maintaining the tile. If the tile is not under the authority of a drainage district, the Approval Authority shall consider the interests of those landowners who are served by the tile.
- F. No STORM SEWER inlet, outlet, or DETENTION BASIN outlet shall be connected to farm drainage tile unless flow is restricted to an amount equal to or less than the discharge capacity of the tile. Such connection shall only be made with the consent and approval of the drainage district responsible for maintaining the tile. If the tile is not under the authority of a drainage district the Approval Authority shall consider the interests of those landowners who are served by the tile.

- G. It shall be unlawful for any person to cause the destruction or obstruction, by act or omission, of the operation of the following, when the following are indicated on the approved engineering drawings for any recorded subdivision plat or other approved site plan, other than by means of a duly approved STORM WATER DRAINAGE PLAN:
1. any STORM WATER DRAINAGE SYSTEM or feature that drains an area of more than five acres; or
 2. any STORM WATER STORAGE AREA.

6.4 Minimum Erosion Control and Water Quality Standards

- A. All CONSTRUCTION or LAND DISTURBANCE shall be provided with EROSION and SEDIMENT controls as necessary to minimize EROSION and SEDIMENTATION on any adjacent property, street, drainage ditch, roadside ditch, or stream. However, the lack of EROSION and SEDIMENT controls shall not itself be a violation of this Ordinance unless such controls are required pursuant to either the requirements of Section 6.4 D, or a LAND DISTURBANCE EROSION CONTROL PERMIT, or a STORM WATER DRAINAGE PLAN, or as such controls may be required by the ZONING ADMINISTRATOR pursuant to an enforcement action based on a valid complaint.
- B. No EROSION AND SEDIMENT CONTROL PLAN shall be required for any CONSTRUCTION or LAND DISTURBANCE unless required pursuant to either a LAND DISTURBANCE EROSION CONTROL PERMIT or a STORM WATER DRAINAGE PLAN or as such controls may be required by the ZONING ADMINISTRATOR pursuant to an enforcement action.
- C. All waste and debris generated as a result of CONSTRUCTION activities including discarded building materials or packaging materials, concrete truck washout, chemicals, litter, sanitary waste, or any other waste, shall be placed in an appropriate waste container in a timely manner, and shall be properly disposed of and shall be prevented from being carried off the SITE by either wind or water.
- D. The following practices shall be applied to LAND DISTURBANCE activities to minimize impacts from stockpiles of soil and other erodible building material (such as sand) containing more than 150 cubic yards of material;
1. Stockpiles of soil and other erodible building material (such as sand) shall be located as follows:
 - a. Stockpiles shall be provided a minimum separation as follows:
 - (a) located not less than 50 feet from the top of the bank of a drainage ditch or stream; and
 - (b) not less than 30 feet from the centerline of a drainage swale that is indicated as an intermittent stream on a United States Geological Survey 7.5 Minute Quadrangle Map; and
 - (c) not less than 30 feet from the top of the bank of a roadside ditch; or and
 - (d) not within a drainage ditch easement; and
 - (e) not less than 30 feet from the nearest property line except for stockpiles on lots less than 150 feet in width and less than 30,000 square feet in area in which case the minimum separation to the nearest property under other ownership is 10 feet provided that erosion and sedimentation controls are installed and maintained as required in Section 11; and

- b. Any additional separation distance required for stabilization and maintenance of the stockpile outside of the minimum separation required above.

- E. No CONSTRUCTION or LAND DISTURBANCE pursuant to CONSTRUCTION shall occur within 50 feet of the top of the bank of a drainage ditch or stream or within 30 feet of the centerline of a drainage swale that is indicated as an intermittent stream (or other drainage feature indicated as an intermittent stream) on a United States Geological Survey 7.5 Minute Quadrangle Map except for the following:
 - 1. Repair and replacement of any lawful CONSTRUCTION that existed on June 19, 2015.
 - 2. Establishment of a filter strip or other landscape maintenance practice or standard that is consistent with Land Disturbance Erosion Controls (Section 11) in this Ordinance and provided that the establishment of the filter strip is coordinated with the Champaign County Soil and Water District Resource Conservationist or an Illinois Licensed Professional Engineer. No permit shall be required pursuant to either this Ordinance or the Zoning Ordinance provided that no other CONSTRUCTION is undertaken and provided that no LAND DISTURBANCE EROSION CONTROL PERMIT is otherwise required.
 - 3. CONSTRUCTION or LAND DISTURBANCE pursuant to a statewide or regional permit administered by the Illinois Department of Natural Resources Office of Water Resources (IDNR/OWR) and provided that information sufficient to document compliance with the relevant statewide or regional permit is submitted to the ZONING ADMINISTRATOR at least one week prior to the start of LAND DISTURBANCE.

- F. Adjacent streets, sidewalks and public areas shall be kept free of SEDIMENT and nuisance soil. Any soil or SEDIMENT tracked onto a street, sidewalk or public area shall be removed before the end of each workday or sooner if directed by the relevant Authority.

6.5 General Enforcement

In the event that any CONSTRUCTION or LAND DISTURBANCE that is not subject to the requirement for a LAND DISTURBANCE EROSION CONTROL PERMIT causes EROSION or SEDIMENTATION on any adjacent property or any adjacent street or adjacent drainage ditch, roadside ditch, or stream, the ZONING ADMINISTRATOR shall take such enforcement actions pursuant to a valid complaint as are necessary and authorized by Section 9.1.1 and Section 10 of the Zoning Ordinance and consistent with Land Disturbance Erosions Controls (Section 11) in this Ordinance to prevent continued EROSION or SEDIMENTATION.

6.6 DEMOLITION PERMIT and GRADING PERMIT

- A. DEMOLITION or GRADING that will result in one acre or more of LAND DISTURBANCE or that is part of a larger COMMON PLAN OF DEVELOPMENT OR SALE OF RECORD which will disturb one acre or more of land, and that is not part of or related to other CONSTRUCTION and that is not located in the Champaign County MS4 JURIDICAL AREA shall be subject to the requirement for either a DEMOLITION PERMIT or a GRADING PERMIT, whichever is applicable.

Champaign County, Illinois
Storm Water Management and Erosion Control Ordinance

- B. Paragraph 6.6A. notwithstanding, the requirements of paragraph 6.1F., Section 6.4, Section 6.5, and paragraph 6.6 J. shall apply to any GRADING or DEMOLITION even though no DEMOLITION PERMIT or GRADING PERMIT may be required based on the amount of LAND DISTURBANCE.
- C. GRADING that is related to DEMOLITION shall be authorized as part of a DEMOLITION PERMIT.
- D. Application for a DEMOLITION PERMIT or a GRADING PERMIT shall be filed in written form with the ZONING ADMINISTRATOR on such forms as the ZONING ADMINISTRATOR prescribes and shall include the following information:
1. Name and address of the OWNER, the APPLICANT, contractor, engineer and architect when applicable;
 2. Location, including township and section, street number, lot block and or tract comprising the legal description of the site;
 3. Permanent Index Number (PIN);
 4. LOT Area;
 5. ZONING DISTRICT;
 6. Special Flood Hazard Area, if applicable;
 7. USE of existing property and structures;
 8. Proposed USE and any proposed structures;
 9. Estimated cost of proposed construction, GRADING, and/or DEMOLITION;
 10. SITE PLAN indicating all existing and proposed USES and structures, water well, septic tank, septic tank leach field;
 11. Extent and nature of proposed LAND DISTURBANCE including a description of any proposed FILL and indication of the general location of any proposed FILL on the SITE PLAN.
- E. Any abandonment of a water well and/or septic tank (or anything similar to a septic tank) shall be in compliance with the Champaign County Health Ordinance and the Illinois Water Well Construction Code (415 ILCS 30) and/or the Illinois Private Sewage Disposal Code (77 ILCS 905.40).
- F. Any abandonment of an underground storage tank shall be in accordance with all applicable laws. This requirement shall not apply to any septic tank.
- G. Any permit for DEMOLITION of a PRINCIPAL BUILDING (as defined in the Champaign County Zoning Ordinance) not related to other CONSTRUCTION shall document the following:
1. Whichever of the following is applicable regarding the presence of a water well on the LOT:
 - a. a written statement that no water well exists on the LOT; or
 - b. a written statement that no water well on the LOT will be abandoned as defined in the Illinois Water Well Construction Code (415 ILCS 30) and the Champaign County Health Ordinance; or
 - c. in the event that a water well on the LOT will be abandoned, a copy of the Water Well Sealing Form pursuant to Public Act 85-0863 shall be submitted.

Champaign County, Illinois
Storm Water Management and Erosion Control Ordinance

2. Whichever of the following is applicable regarding the presence of a septic tank or other similar thing on the LOT:
 - a. a written statement that no septic tank, cesspool, pit privy, aerobic treatment unit, or seepage pit exists on the LOT; or
 - b. a written statement certifying that a septic tank or aerobic treatment unit (or both) or a cesspool or pit privy or seepage pit exists on the LOT and will remain in use; or
 - c. a written statement certifying that a septic tank or aerobic treatment unit (or both), or a cesspool or pit privy or seepage pit exists on the LOT and will no longer be in use and shall be made to comply with the Illinois Private Sewage Disposal Code (77 ILCS 905.40) and the Champaign County Health Ordinance.

- H. Any permit for DEMOLITION of anything other than a privately owned home or ACCESSORY BUILDING or related STRUCTURE or a multi-family DWELLING with four or less dwelling units and/or any ACCESSORY BUILDING shall provide the following to document compliance with the National Emission Standards for Hazardous Air Pollutants (NESHAP):
 1. a written statement by a qualified inspector that regulated removal of asbestos containing material is not necessary; or
 2. if a qualified inspector has determined that regulated removal of asbestos containing material is necessary, a copy of the completed State of Illinois Demolition/Renovation/Asbestos Project Notification Form. All DEMOLITION authorized under a DEMOLITION PERMIT or pursuant to a LDEC PERMIT shall comply with the Illinois Environmental Protection Agency's regulations enforcing the National Emission Standard for Hazardous Air Pollutants for regulated asbestos.

- I. The Applicant for any DEMOLITION is responsible for ending and turning off any relevant utility service prior to DEMOLITION.

- J. Any Zoning Use Permit or Floodplain Development Permit or LDEC PERMIT and all GRADING or DEMOLITION shall comply with the following:
 1. All DEMOLITION debris shall be disposed of lawfully and no CONSTRUCTION or DEMOLITION debris may be buried on the LOT other than as follows:
 - a. Clean CONSTRUCTION or DEMOLITION debris consisting of uncontaminated broken concrete without protruding metal bars, bricks, rock, stone, reclaimed or other asphalt pavement, or soil generated from construction or DEMOLITION activities may be used as a FILL material provided as follows:
 - (a) FILL that includes clean CONSTRUCTION or DEMOLITION debris shall not be placed within any well setback zone established under the Illinois Groundwater Protection Act (415 ILCS 55/1).
 - (b) FILL that includes clean CONSTRUCTION or DEMOLITION debris shall be placed no higher than the adjacent ground elevation that existed prior to the DEMOLITION.
 - (c) The Zoning Administrator may inspect any FILL prior to final grading and must inspect all FILL that is placed inside the MS4 JURISDICTIONAL AREA pursuant to a LDEC PERMIT.

Champaign County, Illinois
Storm Water Management and Erosion Control Ordinance

- (d) FILL that includes clean CONSTRUCTION or DEMOLITION debris shall be covered by sufficient uncontaminated soil to support vegetation within 30 days of the completion of placing the FILL.
 - (e) FILL that includes clean CONSTRUCTION or DEMOLITION debris shall be in compliance with all other requirements of 415 ILCS 5/3.160 and 415 ILCS 5/22.51 or as authorized by the IEPA.
2. All other general CONSTRUCTION or DEMOLITION debris shall be removed from the LOT and taken to a duly approved disposal facility or reused in conformance with 415 ILCS 5/3.160 and 415 ILCS 5/22.51 or as otherwise authorized by the IEPA.
 3. The requirements of paragraph 6.6 G.1. and 6.6 G.2. notwithstanding, uncontaminated broken concrete without protruding metal bars may be used for erosion control consistent with all other standards of this Ordinance.
 4. No DEMOLITION debris shall be burned on the LOT unless all necessary approvals are received from the IEPA in which case a copy of said approval shall be provided with the application.
 5. Fugitive dust shall be minimized during GRADING or DEMOLITION activities.
 6. No open excavation or open basement or foundation more than four feet deep shall be left unfenced at any time and within 90 days shall be removed or filled in conformance with the requirements of this Ordinance so as to be less than four feet deep.
- K. At the time the application is filed for a DEMOLITION PERMIT or a GRADING PERMIT a fee of \$50 shall be paid except that this fee shall be waived provided that a Notice of Intent shall have been submitted to the IEPA and a copy of the Notice of Intent is submitted with the application.
- L. The Applicant for any DEMOLITION PERMIT or any LDEC PERMIT for DEMOLITION not related to other CONSTRUCTION shall notify the Zoning Administrator when the DEMOLITION has been completed and the Zoning Administrator shall inspect the DEMOLITION for compliance with this Ordinance.
- M. EROSION and SEDIMENT controls required by the ZONING ADMINISTRATOR pursuant to an enforcement action shall remain in place and shall be properly maintained in conformance with Section 12.8 until the DEMOLITION or GRADING has achieved FINAL STABILIZATION or until the EROSION and SEDIMENT controls are no longer needed. The ZONING ADMINISTRATOR shall then provide a letter documenting the achievement of FINAL STABILIZATION or that the EROSION and SEDIMENT control are no longer needed. EROSION and SEDIMENT controls required pursuant to the ILR10 shall remain in place until a NOTICE OF TERMINATION has been submitted to the IEPA and the County.

- N. In the event that DEMOLITION or GRADING occurs with no application having been made for a DEMOLITION PERMIT or a GRADING PERMIT, no DEMOLITION PERMIT or GRADING PERMIT shall be required after FINAL STABILIZATION.

7. EASEMENTS

- A. Easements to the County, township, drainage district or other public authority to provide for maintenance of public drainage facilities which serve the SITE and which are or are to be dedicated to, owned by, or under the control of such public authority shall be granted when the need for such facility is in whole or in part specifically and uniquely attributable to the proposed development.
- B. All known agricultural drainage tile located underneath areas to be developed shall be granted an easement if no written easement exists prior to development.
- C. Such easement shall be approved in writing by the public body to which they are granted and recorded in the Champaign County Recorder's Office before the Approval Authority issues any final approval except in the case of SUBDIVISIONS where such easements are shown on the plat.

8. STORM WATER DRAINAGE SYSTEM

8.1 Minor

The minor drainage component of the STORM WATER DRAINAGE SYSTEM shall consist of STORM SEWERS, street gutters, small open CHANNELS, and swales designed to store and convey RUNOFF from the 5-year, 24-hour precipitation event utilizing the Illinois State Water Survey Bulletin 70.

8.2 Major

The major drainage components shall be designed to store and convey STORM WATER beyond the capacity of the minor drainage component. Information depicting STORM WATER paths (including cross-sectional data), velocities, rates, and elevations and maps of flooding shall be included in the submittal as identified in Submittals (Section 9.5).

8.3 Hierarchy of Best Management Practices

The STORM WATER DRAINAGE SYSTEM shall be based on the use of appropriate BEST MANAGEMENT PRACTICES as presented in the Technical Appendices and the following hierarchy of preference with items near the beginning of the hierarchy preferred over items near the end.

- A. Preserve the natural resource features of the DEVELOPMENT SITE (e.g. BEST PRIME FARMLAND, floodplains, wetlands, existing native vegetation) as much as practicable.
- B. Preserve the existing natural streams, CHANNELS and drainage ways as much as practicable.
- C. Minimize IMPERVIOUS surfaces created at the SITE (e.g. using minimum acceptable road width, minimizing driveway length and width, and clustering homes).

- D. Preserve the natural infiltration and storage characteristics of the SITE (e.g. disconnection of IMPERVIOUS cover and on-lot bioretention facilities) as much as practicable.
- E. Use of open vegetated CHANNELS, filter strips, and infiltration to convey, filter, and infiltrate STORM WATER as much as practicable.
- F. Use native vegetation as an alternative to turf grass as much as practicable.
- G. Use structural measures that provide STORM WATER quality and quantity control.
- H. Use structural measures that provide only STORM WATER quantity control and conveyance.

9. STORM WATER DRAINAGE PLAN

9.1 General Design

- A. Design Methods
 - 1. Calculation of Drainage Capacity - The Rational Method may be used to size the minor components for any DEVELOPMENT.
 - 2. Calculation of Required Storage - The volume of required STORM WATER STORAGE AREA shall be calculated on the basis of the maximum value achieved from the RUNOFF of a design event less the volume of water released through the outlet structure.
 - a. DEVELOPMENT WATERSHED Area Less Than or Equal to 10 Acres -The Modified Rational Method shall be acceptable for DEVELOPMENT WATERSHEDS equal to or less than 10 acres in area. In determining the volume of storage required when using the Modified Rational Method, the release rate of the outlet structure shall be assumed to be constant and equal to the release rate through the outlet structure when one half of the storage volume is filled. In determining the maximum allowable release rate for the 50-year event, a runoff coefficient value of 0.25 shall be used for assumed land cover conditions. Roughness coefficients most closely matching those of the TR-55 Method shall be used to determine TIME OF CONCENTRATION.
 - b. DEVELOPMENT WATERSHED Area Less Than or Equal to 2,000 Acres - The method utilized for calculation of required volume of storage shall be the Natural Resources Conservation Service TR-55 Methodology for DEVELOPMENT WATERSHEDS less than or equal to 2,000 acres in area. In determining the maximum allowable release rate for the 50-year event, a curve number shall be used corresponding to the actual SOIL types found on the DEVELOPMENT SITE provided, however, that the land cover "Row crops, SR + CR" in "good" hydrologic condition are assumed. A roughness coefficient of 0.17 and a ponding adjustment factor of 0.72 shall also be assumed in calculating the maximum allowable release rate.
 - c. DEVELOPMENT WATERSHED Area Greater Than 2,000 Acres - DEVELOPMENTS and drainage designs for DEVELOPMENT WATERSHEDS larger than 2,000 acres shall use the Natural Resources Conservation Service TR-20 Methodology. Other routing techniques may be used in determining required storage volume upon the approval of the Approval Authority.
 - d. When applying Natural Resources Conservation Service methods, a SCS Type II rainfall distribution shall be assumed.

- B. Design Event
 - 1. Precipitation values for all RETURN PERIOD storms shall be determined utilizing the Illinois State Water Survey Bulletin 70.
 - 2. A 50-year RETURN PERIOD storm with a 24-hour duration shall be used.
 - 3. When using the Modified Rational Method, the critical storm duration (that requiring the largest detention volume) for any design event shall be identified and used in determining storage volume.
- C. Release Rates
 - 1. Release Rate for Design Event - Outlet structure maximum release rate for the 50-year precipitation event shall be equal to the rate of discharge from the DEVELOPMENT area assuming row crop agricultural land cover and a 5-year RETURN PERIOD precipitation event. See Section 9.1 A for the required assumptions for the row crop agricultural conditions.
 - 2. Effective Discharge for Frequent Storm Events - The outlet structure maximum discharge for each of the 1-year, 2-year and 5-year precipitation events shall be no greater than the rate of discharge from the DEVELOPMENT area, assuming row crop agricultural land cover with the required assumptions described in Section 9.1 A.
 - 3. For all methods of calculating a maximum allowable release rate, the effect of any depressional storage that actually exists on a given SITE shall be included in determination of the TIME OF CONCENTRATION.
- D. Each STORM WATER STORAGE AREA facility shall be provided with a means of overflow. This overflow structure shall be constructed to function without special maintenance attention and can become a part of the excess STORM WATER passageway for the entire DEVELOPMENT.
- E. The entire STORM WATER STORAGE AREA facility shall be designed and constructed to fully protect the public health, safety, and welfare. The minimum building SITE elevation adjacent to wet or dry basins shall be set at a minimum of 1 foot above the maximum created head. The maximum created head will include the energy head at the emergency overflow structure.
- F. STORM WATER STORAGE AREA facilities shall not receive RUNOFF from TRIBUTARY WATERSHEDS outside the DEVELOPMENT SITE unless the Approval Authority determines that RUNOFF from such areas can be accommodated in the storage area in a manner that will protect immediate downstream properties.
- G. Where portions of the OWNER's land are tributary to the same drain for an outlet, but which are within two or more TRIBUTARY WATERSHEDS to that drain, the OWNER may construct, upon site specific approval by the Approval Authority, compensatory STORM WATER detention facilities within one TRIBUTARY WATERSHED which offset the lack of CONSTRUCTION of STORM WATER detention facilities in another TRIBUTARY WATERSHED. Such compensatory storage shall be designed and constructed such that the net effect of these facilities shall be to limit the rate at which STORM WATER is released into the drain to that rate which would have occurred had STORM WATER detention facilities been constructed for all the TRIBUTARY WATERSHEDS.

9.2 Dry Bottom Storm Water Storage Areas

- A. DRY BOTTOM STORM WATER DETENTION BASINS should be designed where possible to serve a secondary purpose for recreation, open space, or similar types of uses which will not be adversely affected by occasional intermittent flooding and will not interfere with STORM WATER MANAGEMENT.

Champaign County, Illinois
Storm Water Management and Erosion Control Ordinance

- B. Minimum grades for turf areas within the basin shall be 2 percent (50 units horizontal to one unit vertical) except that the minimum GRADE shall be 1 percent (100 units horizontal to one unit vertical) if tile underdrains are adequately installed underneath the turf areas. Storage facility side SLOPES shall not exceed 3:1 (three units horizontal to one unit vertical), shall provide for the reasonably safe approach of persons and reasonably safe maintenance practices. Side SLOPES steeper than 3:1 may be allowed upon a determination by the Approval Authority that adequate precautions are taken to avoid unreasonable hazard. Storage basin excavations shall follow the natural land contours as closely as practicable. The geometry of DRY BOTTOM STORM WATER DETENTION BASINS shall be approved by the Approval Authority.
- C. Temporary seeding or other SOIL stabilization measures shall be established in the STORM WATER STORAGE AREA and excess STORM WATER passageway immediately following the CONSTRUCTION or RECONSTRUCTION of these facilities. These measures shall conform to Land Disturbance Erosion Controls (Section 11) in this Ordinance. During the construction of the overall DEVELOPMENT, it is recognized that a limited amount of SEDIMENT buildup may occur in the STORM WATER STORAGE AREA due to EROSION. In no case, shall the volume of the storage basin be reduced to less than 90 percent of the required volume during the CONSTRUCTION phase of the DEVELOPMENT. Basins may be over-excavated to provide additional storage volume for anticipated SEDIMENTATION during CONSTRUCTION activities.
- D. Permanent EROSION control measures such as hydro seeding, conventional seeding, nurse crops, fertilizing, or sod installation and associated stabilization techniques such as mulching shall be utilized to control SOIL movement and EROSION within the storage area and excess STORM WATER passageway as required. These measures shall conform to Land Disturbance Erosion Controls (Section 11) in this Ordinance. The installation of these permanent measures shall take place only after the majority of CONSTRUCTION and other silt and SEDIMENT producing activities have been completed.
- E. Prior to the establishment of permanent EROSION control measures, the required capacity of the STORM WATER STORAGE AREA and the excess STORM WATER passageway shall, if necessary, be restored by EXCAVATION of SEDIMENT materials to provide 100 percent of the required storage volume. Upon completion of CONSTRUCTION activities, the storage volume shall be certified in writing by an Illinois Registered Professional Engineer prior to the issuance of any Compliance Certificate required by Section 9.1.3 of the Champaign County Zoning Ordinance for any DEVELOPMENT served by such basin. The specific EROSION control measures to be employed shall be included in an ESCP to be approved by the Approval Authority.
- F. The outlet CONTROL STRUCTURE shall be provided with an interceptor for trash and debris, and it shall be designed and constructed to minimize EROSION and not to require manual adjustments for its proper operation. The CONTROL STRUCTURE shall be designed to operate properly with minimal maintenance or attention. The CONTROL STRUCTURE shall be provided with safety screens for any pipe or opening, other than a weir, to prevent children or large animals from crawling into structures. The CONTROL STRUCTURE shall be constructed to allow access to it at all times, including times of flood flow.
- G. Paved low flow conduits shall be provided in STORM WATER STORAGE AREA. These conduits shall be so constructed that they will not unnecessarily interfere with any secondary use of the storage area and will reduce the frequency of time that the storage

- area will be covered with water and facilitate dewatering of the SOILS in the STORM WATER STORAGE AREA to avoid saturated SOIL conditions. Low flow conduits shall facilitate complete interior drainage of the STORM WATER STORAGE AREA. Tile underdrain systems may be combined with the low flow conduits or CHANNEL systems.
- H. Pipe outlets of less than 10 inches in diameter shall not be allowed unless specifically approved by the Approval Authority. Multiple outlet pipes from a STORM WATER STORAGE AREA shall be avoided if they are designed to be less than 12 inches in diameter.
 - I. Warning signs shall be placed at appropriate locations to warn of deep water, possible flood conditions during storm periods, and of other dangers that exist to pedestrian and vehicular traffic.

9.3 Wet Bottom Storm Water Storage Areas

WET BOTTOM STORM WATER STORAGE AREAS shall be designed in compliance with all the applicable regulations which govern the CONSTRUCTION of DRY BOTTOM STORM WATER DETENTION BASINS. The following additional regulations shall apply to WET BOTTOM STORM WATER STORAGE AREAS:

- A. The water surface area of the permanent pool shall not exceed one-fifth of the area of the TRIBUTARY WATERSHED, or as approved by the Approval Authority.
- B. Minimum normal water depth (excluding safety ledges and side SLOPES) shall be eight feet provided, however, that if fish are to be maintained in the pond, at least one-quarter of the pond area shall be a minimum of ten feet deep.
- C. Measures shall be included in the design to minimize pond stagnation and to help ensure adequate aerobic pond conditions.
- D. All WET BOTTOM STORM WATER STORAGE AREAS shall comply with the requirements for some combination of vertical barrier or safety ledge for all pools as required by Section 4.3.6 of the Champaign County Zoning Ordinance.

9.4 Alternative Storm Water Storage Areas

The use of STORM WATER STORAGE AREAS as described in Dry Bottom Storm Water Storage Areas (Sections 9.2) and Wet Bottom Storm Water Storage Areas (Section 9.3) are the preferred means of STORM WATER storage. The following alternative means of STORM WATER storage may be used on DEVELOPMENT SITES under 2 acres in area or where practical necessity makes the use of STORM WATER STORAGE AREAS infeasible. The use of such alternative STORM WATER STORAGE AREAS is only permitted upon the specific approval of the Approval Authority. Storage of STORM WATER in public streets will not be allowed.

- A. Paved STORM WATER Storage - Design and CONSTRUCTION of the pavement base must insure that there is minimal pavement damage due to flooding. CONTROL STRUCTURES in paved areas must be readily accessible for maintenance and cleaning. Flow control devices will be required unless otherwise approved by the Approval Authority.
- B. Street Pavement Surface Ponding - Street pavement surface ponding shall not exceed 9 inches in depth in the gutter line nor over the roadway crown if no gutter is present under all rainfall conditions up to and including the 50-year storm event. Open waterways such as surface overflow swales shall be designed into the GRADING plan to receive all excess STORM WATER. Depressing sidewalks across such overflow swales to meet this requirement shall be acceptable. Street ponding shall be allowed only for the conveyance of RUNOFF and will be subject to approval by the public body accepting dedication of the street.

- C. Rooftop STORM WATER Storage - Rooftop storage of excess STORM WATER shall be designed and constructed to provide permanent control inlets and parapet walls to contain excess STORM WATER. Adequate structural roof design must be provided to ensure that roof deflection does not occur which could cause the roofing material to fail and result in leakage. Overflow areas must be provided to ensure that the weight of STORM WATER will never exceed the structural capacity of the roof. Any rooftop storage of excess STORM WATER shall be approved only upon submission of building plans signed and sealed by a licensed structural engineer or architect attesting to the structural adequacy of the design.
- D. Automobile Parking Lot Storage Areas - Automobile parking lots may be designed to provide temporary detention storage on a portion of their surfaces. Automobile parking facilities used to store excess STORM WATER may be constructed having a maximum depth of stored STORM WATER of 0.6 feet; and these areas shall be located in the most remote, least used areas of the parking facility. Design and CONSTRUCTION of automobile parking in STORM WATER areas must insure that there is minimal damage to the parking facility due to flooding, including minimal damage to the sub base. Warning signs shall be mounted at appropriate locations to warn of possible flood conditions during storm periods.
- E. Underground STORM WATER Storage - Underground STORM WATER storage facilities must be designed for easy access in order to remove accumulated SEDIMENT and debris. These facilities must be provided with a positive gravity outlet unless otherwise approved by the Approval Authority.

9.5 Submittals

Two copies of a STORM WATER DRAINAGE PLAN prepared by an Illinois Professional Engineer must be submitted with any zoning petition or SUBDIVISION application where required by this Ordinance. Such plan must at a minimum contain the following:

- A. The SUBDIVISION name or other project identification, engineer's firm, the engineer's name, and date shall all be indicated.
- B. Full description of before and after DEVELOPMENT topography, existing drainage (including locations of agricultural drainage tile serving the area to be developed as well as serving off-site areas but which crosses the area to be developed as well as the efforts to identify and locate underground tile), GRADING, and environmental characteristics of the property. This includes but is not limited to the location and size of all landscaped and vegetated areas, green roofs, rain water storage systems, and areas of permeable surfacing intended to provide storm water treatment or other storm water control.
- C. An explanation of the minor and major STORM WATER DRAINAGE SYSTEMS' performance under storm events up to and including the 100-year precipitation event and of the provisions for handling drainage from any TRIBUTARY WATERSHEDS.
- D. The potential impacts of the DEVELOPMENT on water resources both upstream and downstream.
- E. STORM WATER Detention or Retention System Designs - Calculations shall be submitted with all assumptions, coefficients, and other parameters identified and their sources noted.
- F. For detention systems for DEVELOPMENTS of more than 10 acres in area, a plot or tabulation of storage volumes with corresponding water surface elevations (stage storage table) and of the basin outflow rates for those water surface (stage discharge) elevations shall be furnished for the 1-year, 2-year, 5-year and 50-year precipitation events. These tabulations shall be listed for water surface elevation intervals not exceeding 1.0 foot.

- G. ESCP as required by LDEC Permits (Section 12) in this Ordinance.

9.6 Certifications

The following certifications shall be submitted prior to the issuance of any Certificate of Compliance, final plat approval, or release of performance guarantee for DEVELOPMENT on the SITE as provided in the applicable provisions of the Champaign County Zoning Ordinance or Champaign County Subdivision Regulations:

- A. Certification of storage volume as required in Section 9.2E.
- B. As-built drawings of the STORM WATER DRAINAGE SYSTEM including the storage facility in sufficient detail to determine that the constructed facility is substantially the same as that presented in the approved STORM WATER DRAINAGE PLAN with certification to that effect by an Illinois Professional Engineer.

10. JOINT CONSTRUCTION

STORM WATER STORAGE AREAS may be planned and constructed jointly by two or more landowners so long as compliance with this Ordinance is maintained.

11. LAND DISTURBANCE EROSION CONTROL

11.1 General Requirement

- A. Land Disturbance Erosion Control requirements shall apply to any STORM WATER DRAINAGE PLAN, LDEC PERMIT or enforcement actions prescribed by the Zoning Administrator.
- B. The design, testing, installation, and maintenance of EROSION and SEDIMENT control operations and facilities shall adhere to the requirements of this Ordinance and the standards and specifications contained in the Technical Appendices; and to the most recent version of the ILLINOIS URBAN MANUAL. This Ordinance shall prevail where any of those requirements conflict. The EROSION and SEDIMENT control standards specifically included in this Ordinance may not be adequate for every situation that may be encountered and in those situations the most appropriate standard(s) from the ILLINOIS URBAN MANUAL should be utilized.

11.2 Minimize Soil Erosion

The following practices shall be applied to LAND DISTURBANCE activities to minimize Soil Erosion.

- A. LAND DISTURBANCE shall be minimized to the extent practical and shall be conducted in such a manner as to minimize soil EROSION.
- B. Prior to any LAND DISTURBANCE on the SITE, EROSION control facilities shall be installed.
- C. Areas of LAND DISTURBANCE shall be stabilized immediately whenever LAND DISTURBANCE has permanently ceased on any portion of the SITE, or temporarily ceased on any portion of the SITE and will not resume for a period exceeding 14 calendar days. Stabilization of disturbed areas must be initiated within 1 working day of permanent or temporary cessation of earth disturbing activities and shall be completed as soon as possible but not later than 14 days from the initiation of stabilization work in the area. Except where the initiation of stabilization measures is precluded by snow cover, stabilization measures shall be initiated as soon as practicable or on areas where

construction activity has temporarily ceased and will resume after 14 days, a temporary stabilization method can be used.

- D. Appropriate temporary or permanent stabilization measures shall include seeding, mulching, sodding, and/or non-vegetative measures.
- E. Areas of LAND DISTURBANCE with a slope equal to or greater than three feet horizontal to one foot vertical shall be stabilized.
- F. To the extent practicable, ditches and swales which are to convey off-site flows through the SITE shall be stabilized upon construction.
- G. The condition of the LAND DISTURBANCE and/ or construction SITE for the winter shutdown period shall address proper EROSION and SEDIMENT control early in the fall growing season so that all LAND DISTURBANCE areas may be stabilized with temporary or permanent vegetative cover.
 - 1. All non-active construction areas that are to remain idle throughout the winter shall receive temporary erosion control measures including temporary seeding, mulching, and/or erosion control blanketing prior to the end of the fall growing season that is approximately October 15.
 - 2. Those active construction areas to be worked beyond October 15 shall incorporate soil stabilization measures that do not rely on vegetative cover such as erosion control blanketing and heavy mulching.

11.3 Minimize Sedimentation

The following practices shall be applied to LAND DISTURBANCE activities to minimize SEDIMENTATION:

- A. SEDIMENT control facilities shall be utilized to minimize SEDIMENT from leaving the SITE and minimize the amount of sediment being moved on the SITE.
- B. Common SEDIMENT control facilities or structures are sediment traps, sediment basins, and silt fences. Straw bale dikes are not authorized SEDIMENT control facilities.
- C. SEDIMENT control facilities shall be in place for all drainage leaving the SITE prior to mass GRADING.
- D. Adjacent private and public areas shall be kept free of SEDIMENT and nuisance soil. A stabilized LOT or construction entrance (driveway) and vehicle wash down facilities, if necessary, shall be provided to minimize the amount of soil and SEDIMENT tracked onto public or private streets. Any soil or SEDIMENT tracked onto a public or private street shall be removed before the end of each workday or sooner if directed by the relevant Authority.
- E. When a proposed LAND DISTURBANCE is tributary to a storm drain inlet, that storm drain inlet shall be protected by an appropriate SEDIMENT control device prior to the LAND DISTURBANCE.

11.4 Construction Dewatering

Water that is pumped or otherwise discharged on or from the SITE during construction dewatering shall be filtered to remove SEDIMENT and erosion shall be minimized.

11.5 Stockpiles

Stockpiles of soil and other erodible building material (such as sand) of 100 cubic yards or more shall be stabilized with temporary or permanent measures of EROSION and SEDIMENT control within 14 calendar days and shall be located as follows:

- A. Stockpiles shall be provided a minimum separation of not less than 50 feet from the top of the bank of a drainage ditch or stream and not less than 30 feet from the centerline of

a drainage swale that is indicated as an intermittent stream (or other drainage feature indicated as an intermittent stream) on a United States Geological Survey 7.5 Minute Quadrangle Map and not less than 30 feet from the top of the bank of a roadside ditch or and not in a drainage ditch easement and not less than ~~30~~ 10 feet from the nearest property line under other ownership; and

- B. Any additional separation distance required for stabilization and maintenance of the stockpile outside of the minimum separation required above.

11.6 Required Maintenance of Erosion and Sediment Control Measures

All temporary EROSION and SEDIMENT control measures shall be inspected regularly and maintained in an effective working condition at least as frequently (and more often if needed) as follows:

- A. Repair, replace, or maintain EROSION and SEDIMENT control measures after a singular or cumulative rainfall event of 0.5 inches or more over a 24 hour period.
- B. All temporary EROSION and SEDIMENT control measures shall be removed within 30 days after FINAL STABILIZATION is achieved with permanent soil stabilization measures.
- C. Trapped SEDIMENT and other disturbed soil resulting from temporary measures shall be properly disposed of and the area shall be stabilized.

12. LDEC PERMITS

- A. Within the Champaign County MS4 JURISDICTIONAL AREA, a LDEC PERMIT shall be required for applicable LAND DISTURBANCES except activities identified in LDEC Permit Exemptions (Section 4.4).
- B. The requirements and review procedures to authorize a particular LAND DISTURBANCE depend upon the classification of that particular LAND DISTURBANCE. LDEC PERMITS shall be of the following types:
 1. A MAJOR LDEC PERMIT shall be required for any LAND DISTURBANCE of one acre or more of land within the Champaign County MS4 JURISDICTION.
 2. A MINOR LDEC PERMIT shall be required for any LAND DISTURBANCE of less than one acre of land but greater than 10,000 square feet that is part of a COMMON PLAN OF DEVELOPMENT OR SALE OF RECORD or that is part of any other USE, DISTRICT, or LOT described in Applicability (Section 4.1), that is not otherwise identified in LDEC Permit Exemptions (Section 4.4).
 3. LDEC PERMITS are required to be obtained by the OWNER or DEVELOPER of each LOT of a COMMON PLAN OF DEVELOPMENT OR SALE OF RECORD, if multiple LAND DISTURBANCE activities occurring at the same time will result in 1 acre or greater LAND DISTURBANCE.

12.0 Applications for a LDEC Permit

Applications for a LDEC PERMIT shall be filed in written form with the ZONING ADMINISTRATOR on such forms as the ZONING ADMINISTRATOR prescribes and shall include the following:

- A. Name and address of the OWNER, the APPLICANT, contractor, engineer and architect when applicable;
- B. Location, including township and section, street number, lot block and or tract comprising the legal description of the SITE;
- C. Permanent Index Number (PIN);

- D. LOT Area;
- E. ZONING DISTRICT;
- F. Special Flood Hazard Area, if applicable;
- G. Use of existing property and structures;
- H. Proposed use and any proposed structures;
- I. Estimated cost of proposed construction;
- J. SITE PLAN indicating all existing and proposed uses and structures;
- K. Extent and nature of proposed LAND DISTURBANCE;
- L. An EROSION AND SEDIMENT CONTROL PLAN (ESCP) meeting the requirements of this Ordinance;
- M. Applications for a Major LDEC PERMIT shall also include the Supplemental Application Form in Technical Appendix E.

12.1 LDEC Permit - Minor

The following forms and procedures are required:

- A. The APPLICANT shall submit a completed Application Form. Copies of the completed and approved Application Form and LETTER OF NOTIFICATION shall be kept on the project SITE and made available for public viewing during CONSTRUCTION hours.
- B. Submission of an ESCP consistent with the guidelines and standards in Technical Appendix D.
- C. Upon approval of the ESCP by the ZONING ADMINISTRATOR, the ESCP shall be implemented by the PERMITTEE consistent with the guidelines and standards in Technical Appendix D.
- D. The PERMITTEE shall allow inspections of the LAND DISTURBANCE by the ZONING ADMINISTRATOR as indicated in Required Inspections (Section 13.5) in this Ordinance.
- E. When the LAND DISTURBANCE is completed and all LAND DISTURBANCE on the project SITE has received FINAL STABILIZATION, a LETTER OF TERMINATION shall be submitted by the PERMITTEE to the ZONING ADMINISTRATOR.

12.2 LDEC Permit - Major

The following forms and procedures are required:

- A. Submission of a completed Application Form and Supplemental Land Disturbance Erosion Control Permit Application Form. Copies of the completed and approved Application Form, SWPPP and ESCP shall be kept on the project SITE and made available for public viewing during CONSTRUCTION hours.
- B. The APPLICANT shall complete a NOTICE OF INTENT according to the ILR10 requirements and submit the NOI to the IEPA and the County.
- C. The APPLICANT shall complete a CONTRACTOR'S CERTIFICATION STATEMENT (CCS) according to the ILR10 requirements and submit the CCS to the IEPA and the County.
- D. The APPLICANT shall prepare a SWPPP according to the ILR10 requirements and submit the written SWPPP to the IEPA and the County.
- E. The APPLICANT shall submit an ESCP that has been prepared by a licensed PROFESSIONAL ENGINEER or a CERTIFIED PROFESSIONAL EROSION CONTROL SPECIALIST, for approval by the ZONING ADMINISTRATOR. The ESCP shall be as follows:
 - 1. The ESCP shall be drawn to an appropriate scale and shall include sufficient information to evaluate the environmental characteristics of the affected areas,

the potential impacts of the proposed GRADING on water resources, and measures proposed to minimize SOIL EROSION and minimize offsite EROSION and SEDIMENTATION.

2. The following information shall be included in any ESCP:
 - a. A letter of transmittal, which includes a project narrative.
 - b. An attached vicinity map showing the location of the SITE in relationship to the surrounding area's WATERCOURSES, water bodies and other significant geographic features, roads and other significant STRUCTURES.
 - c. An indication of the scale used and a north arrow.
 - d. The name, address, and telephone number of the OWNER and/or DEVELOPER of the property where the land disturbing activity is proposed.
 - e. Suitable contours for the existing and proposed topography.
 - f. Types of SOILS present on the SITE, as defined by the "Soil Survey of Champaign County, Illinois", prepared by the United States Department of Agriculture Natural Resources Conservation Service.
 - g. The proposed GRADING or LAND DISTURBANCE activity including; the surface area involved, excess spoil material, use of BORROW material, and specific limits of disturbance.
 - h. Location of WASHOUT FACILITIES for concrete and asphalt materials indicated on the SITE PLAN. Provide details of proposed WASHOUT FACILITIES.
 - i. A clear and definite delineation of any areas of vegetation or trees to be saved.
 - j. A clear and definite delineation of any WETLANDS, natural or artificial water storage detention areas, and drainage ditches on the SITE.
 - k. A clear and definite delineation of any 100-year FLOODPLAIN on or near the SITE.
 - l. STORM WATER DRAINAGE SYSTEMS, including quantities of flow and SITE conditions around all points of SURFACE WATER discharge from the SITE.
 - m. EROSION and SEDIMENT control provisions to minimize on-site EROSION and SEDIMENTATION and minimize off-site EROSION and SEDIMENTATION, including provisions to preserve TOPSOIL and limit disturbance. Provisions shall be in accordance with the standards presented in the appropriate Technical Appendix.
 - n. Design details for both temporary and permanent EROSION CONTROLS. Details shall be in accordance with the standards presented in the appropriate Technical Appendix.
 - o. Details of temporary and permanent stabilization measures including a note on the plan stating: "Following initial SOIL disturbance or redisturbance, permanent or temporary stabilization shall be completed within seven (7) calendar days on all perimeter dikes, swales, ditches, perimeter SLOPES, and all SLOPES greater than three (3) horizontal to one (1) vertical (3:1); embankments of ponds, basins, and traps; and within fourteen (14) days on all other disturbed or graded areas. The requirements of this section do not apply to those areas which are shown on the plan and are currently being used for material storage or for those areas on which actual CONSTRUCTION activities are currently being performed."
 - p. A chronological schedule and time frame (with estimated month) including, as a minimum, the following activities:

Champaign County, Illinois
Storm Water Management and Erosion Control Ordinance

- i. CLEARING AND GRUBBING for those areas necessary for installation of perimeter EROSION control devices.
 - ii. CONSTRUCTION of perimeter EROSION control devices.
 - iii. Remaining interior SITE CLEARING AND GRUBBING.
 - iv. Installation of permanent and temporary stabilization measures.
 - v. Road GRADING.
 - vi. GRADING for the remainder of the SITE.
 - vii. Building, parking lot, and SITE CONSTRUCTION.
 - viii. Final GRADING, landscaping or stabilization.
 - ix. Implementation and maintenance of FINAL STABILIZATION.
 - x. Removal of temporary EROSION control devices.
 - q. A statement on the plan noting that the CONTRACTOR, DEVELOPER, and OWNER shall request the EROSION CONTROL INSPECTOR to inspect and approve work completed in accordance with the approved ESCP, and in accordance with the ordinance.
 - r. A description of, and specifications for, SEDIMENT retention structures.
 - s. A description of, and specifications for, surface RUNOFF and EROSION control devices.
 - t. A description of vegetative measures.
 - u. A proposed vegetative condition of the SITE on the 15th of each month between and including the months of April through October.
 - v. The seal of a licensed PROFESSIONAL ENGINEER in the State of Illinois, if applicable.
- F. The APPLICANT may propose the use of any EROSION and SEDIMENT control techniques in a FINAL ESCP, provided such techniques are proved to be as or more effective than the equivalent BEST MANAGEMENT PRACTICES as contained in the manual of practices.
- G. The PERMITTEE shall prepare an EROSION CONTROL INSPECTION REPORT (ECIR) on a weekly basis or after any rainfall event one-half (1/2) inch or greater in twenty-four (24) hours, as recorded on-site, at the nearest United States Geologic Survey or Illinois State Water Survey rain gauge nearest the SITE. Submit the ECIR to the ZONING ADMINISTRATOR within five (5) days. Inspections may be reduced to once per month when construction activities have ceased due to frozen conditions. Weekly inspections will recommence when construction activities are conducted, or if there is one-half (1/2) inch or greater rain event, or snowmelt occurs.
- H. The PERMITTEE shall prepare an INCIDENCE OF NON-COMPLIANCE (ION) report within forty-eight (48) hours for any non-compliance. The ION report shall meet all ILR10 requirements. Submit the ION to the IEPA and the County.
- I. Copies of the documents listed above shall be kept on the project SITE and shall be made available for public viewing during CONSTRUCTION hours.
- J. The PERMITTEE shall prepare a NOTICE OF TERMINATION (NOT) upon FINAL STABILIZATION of the project SITE. Submit the NOT to the IEPA and the County.
- K. All reports should be mailed to the ZONING ADMINISTRATOR at the following address:
- Department of Planning and Zoning
Brookens Administrative Center
1776 E. Washington St.
Urbana, IL 61802

12.3 Fee

At the time the application is filed a fee shall be paid in accordance with the following schedule of fees in addition to any Zoning Use Permit fees that may apply:

- A. LDEC PERMIT - MAJOR
 - 1. No additional fee is required if a STORM WATER DRAINAGE PLAN is required and a fee has been paid in accordance with Section 9.3.4 of the Zoning Ordinance.
 - 2. If no STORM WATER DRAINAGE PLAN is required the fee shall be the Engineering Review Fee established by Section 9.3.4 of the Zoning Ordinance.
- B. LDEC PERMIT - MINOR.....\$50.00

12.4 LDEC Permit Authorization

The issuance of a LDEC PERMIT shall constitute an authorization to do only the work described in the PERMIT or shown on the approved SITE PLANS and specifications, all in strict compliance with the requirements of this ordinance and conditions determined by the Zoning Administrator.

12.5 LDEC Permit Duration

- A. LDEC PERMITS shall be issued for a specific period of time, up to one (1) year. The LDEC PERMIT duration shall reflect the time the proposed land disturbing or filling activities and SOIL storage are scheduled to take place. If the PERMITTEE commences permitted activities later than one hundred eighty (180) days of the scheduled commencement date for GRADING, the PERMITTEE shall resubmit all required application forms, maps, plans, and schedules to the ZONING ADMINISTRATOR. The PERMITTEE shall fully perform and complete all of the work required in the sequence shown on the plans within the time limit specified in the LDEC PERMIT.
- B. LAND DISTURBANCE activities that require schedules in excess of one (1) year shall be reviewed and authorized by the ZONING ADMINISTRATOR in accordance with paragraph 9.1.2 D. of the Zoning Ordinance.

12.6 Responsibility of the Permittee

- A. The PERMITTEE shall maintain a copy of the LDEC PERMIT, approved plans and reports required under the LDEC PERMIT on the work SITE and available for public inspection during all working hours. The PERMITTEE shall, at all times, ensure that the property is in conformity with the approved GRADING plan, ESCP's, and with the following:
 - 1. General - Notwithstanding other conditions or provisions of the LDEC PERMIT, or the minimum standards set forth in this Ordinance, the PERMITTEE is responsible for the prevention of damage to adjacent property arising from LAND DISTURBANCE activities. No person shall GRADE on land in any manner, or so close to the property lines as to endanger or damage any adjoining public street, sidewalk, alley or any other public or private property without supporting and protecting such property from settling, cracking, EROSION, SEDIMENTATION or other damage or personal injury which might result.
 - 2. Public ways - The PERMITTEE shall be responsible for the prompt removal of any SOIL, miscellaneous debris or other materials washed, spilled, tracked, dumped or otherwise deposited on public streets, highways, sidewalks, public thoroughfare or public sanitary or STORM WATER conveyance systems, incident to the CONSTRUCTION activity, or during transit to and from the SITE and shall promptly correct any damages resulting therefrom.

- B. Compliance with this Ordinance does not ensure compliance with ILR10 requirements. APPLICANT and/or PERMITTEE is responsible for ensuring compliance with ILR10 requirements.

12.7 Required Maintenance During and After Construction

On any property on which GRADING or other work has been performed pursuant to a LDEC PERMIT granted under the provisions of this Ordinance, the PERMITTEE or OWNER, their agent, CONTRACTOR, and employees shall, at a minimum, daily inspect, maintain and repair all graded surfaces and EROSION control facilities, drainage structures or means and other protective devices, plantings, and ground cover installed while CONSTRUCTION is active. After CONSTRUCTION is complete, the OWNER or their agent shall maintain erosion control facilities and other drainage structures. This shall include cleaning inlets at least once a year during spring time and SEDIMENT shall be removed every 15 years or as needed.

13. ADMINISTRATION OF LDEC PERMITS

13.1 Zoning Administrator

- A. Administration and enforcement of this Ordinance shall be governed by the requirements of this Ordinance and Section 9 of the Champaign County Zoning Ordinance. This Ordinance shall prevail where there is a conflict but the Zoning Ordinance shall prevail where this Ordinance is silent.
- B. The ZONING ADMINISTRATOR, as defined in Section 9.1.1 of the Zoning Ordinance, shall have the duty to administer and enforce this Ordinance.
- C. The ZONING ADMINISTRATOR representative is authorized to make inspections of any SITE at various times on which there is a LAND DISTURBANCE that is regulated by this Ordinance. The intent of entering premises is to inspect the SITE before, during and after CONSTRUCTION to determine compliance with this Ordinance.

13.2 Conditions of Approval

In granting any LDEC PERMIT pursuant to this Ordinance, the ZONING ADMINISTRATOR may impose such conditions as may be reasonably necessary to prevent the creation of a nuisance or unreasonable hazard to persons or to a public or private property. Such conditions may include, but need not be limited to:

- A. The granting (or securing from others) and the recording in county land records of easements for drainage facilities, including the acceptance of their discharge on the property of others, and for the maintenance of SLOPES or EROSION control facilities.
- B. Adequate control of dust by watering, or other control methods acceptable to the ZONING ADMINISTRATOR, and in conformance with applicable air pollution ordinances.
- C. Improvements of any existing GRADING, ground surface or drainage condition on the SITE (not to exceed the area as proposed for work or DEVELOPMENT in the application) to meet the standards required under this Ordinance for new GRADING, drainage and EROSION control.
- D. SEDIMENT traps and basins located within a densely populated area or in the proximity of an elementary school, playground or other area where small children may congregate without adult supervision, may be required to install additional safety-related devices.
- E. Any other EROSION and SEDIMENT control technique necessary, in the opinion of the ZONING ADMINISTRATOR, to avoid a public safety hazard.

13.3 LDEC Permit Denial

- A. If the ZONING ADMINISTRATOR determines that an ESCP does not meet the requirements of this Ordinance, the application for the LDEC PERMIT shall not be approved.
- B. The ESCP must be resubmitted and approved before any LAND DISTURBANCE activity may be authorized.
- C. All land use and building permits shall be suspended on a SITE until there is an approved ESCP and the ZONING ADMINISTRATOR has approved a LDEC PERMIT.

13.4 Changes to LDEC Permits and Plans

- A. No work associated with any proposed modification to a LDEC PERMIT or plan shall occur without prior written approval by the ZONING ADMINISTRATOR.
- B. Administrative changes such as contact information or schedule changes must be submitted prior to, or together with, any reports, information, or applications to be signed by and authorized representative, but does not require review or approval by the ZONING ADMINISTRATOR.
- C. Changes to an approved ESCP can be authorized in two (2) ways:
 - 1. Changes within the scope of the applicable Technical Appendix may be approved and documented on a field inspection report signed and dated by the EROSION CONTROL INSPECTOR.
 - 2. Changes outside of the scope of the applicable Technical Appendix shall be submitted to the ZONING ADMINISTRATOR for approval.

13.5 Required Inspection

- A. All work for which a LDEC PERMIT is required shall be subject to inspection and approval by the ZONING ADMINISTRATOR. Refusal to allow entry of the ZONING ADMINISTRATOR or his/her representative to inspect for compliance with this Ordinance, or interference with such inspection, shall be grounds for the issuance of a STOP-WORK ORDER.
- B. The PERMITTEE and/or their agents shall conduct a pre-CONSTRUCTION meeting on SITE with the EROSION CONTROL INSPECTOR on each SITE which has an approved ESCP.
- C. The PERMITTEE shall obtain written inspection approvals by the EROSION CONTROL INSPECTOR at the following stages in the DEVELOPMENT of the SITE, or of each SUBDIVISION thereof:
 - 1. Upon completion of installation of perimeter EROSION and SEDIMENT controls and prior to proceeding with any other LAND DISTURBANCE or GRADING. Other building or GRADING inspection approvals, including approval of any related Zoning Use Permit, shall not be authorized until the installation of perimeter EROSION and SEDIMENT controls has been approved by the EROSION CONTROL INSPECTOR.
 - 2. Upon completion of stripping, the stockpiling of TOPSOIL, the CONSTRUCTION of temporary EROSION and SEDIMENT control facilities, disposal of all waste material, and preparation of the ground and completion of rough GRADING, but prior to placing TOPSOIL, permanent drainage or other SITE DEVELOPMENT improvements and ground covers.
 - 3. Upon completion of FINAL STABILIZATION, including GRADING, permanent drainage and EROSION control facilities, including established ground covers and plantings, and all other work of the LDEC PERMIT.

4. The ZONING ADMINISTRATOR may require additional inspections as may be deemed necessary.
- D. Work shall not proceed beyond the stages outlined above until the EROSION CONTROL INSPECTOR inspects the SITE and approves the work previously completed.
- E. Requests for inspections shall be made at least twenty-four (24) hours in advance (exclusive of Saturdays, Sundays, and holidays) of the time the inspection is desired. Upon request for inspections, the EROSION CONTROL INSPECTOR shall perform the inspection within forty-eight (48) hours of the request.
- F. The inspection to determine compliance with this Ordinance shall not normally include a new building which was completed and which has been secured, but shall include inspection of any area of the property where land disturbing activity is occurring or has been authorized

14. LIABILITY RELATED TO LDEC PERMITS

- A. Neither the issuance of a LDEC PERMIT under the provisions of this Ordinance, nor the compliance with the provisions hereto or with any condition imposed by the ZONING ADMINISTRATOR, shall relieve any person from responsibility for damage to persons or property resulting from the activity of the PERMITTEE.
- B. Compliance with the conditions imposed by this Ordinance, or conditions imposed by the ZONING ADMINISTRATOR, shall not create liability on the County resulting from such compliance.

15. ENFORCEMENT OF LDEC PERMITS

15.1 Compliance

The PERMITTEE shall carry out the proposed work in accordance with the approved plans and specifications, and in compliance with all the requirements of the LDEC PERMIT, including those documents referenced in this Ordinance.

15.2 Deficiency

A SITE is deficient when regular maintenance of EROSION and SEDIMENT CONTROLS have not been completed and can generally be resolved during weekly inspections or inspections following storm events. The ZONING ADMINISTRATOR may send a letter encouraging the PERMITTEE to fix the deficiency before the next rain event when the SITE may become non-compliant.

15.3 Non-Compliance

A SITE is Non-Compliant when any violation of the stormwater pollution prevention plan or any condition of applicable permits is observed during any inspection. Corrective actions must be undertaken immediately to address the identified non-compliance issue(s). Any incidence of noncompliance (ION) shall be reported to the IEPA as required by the ILR10 permit and to the Zoning Administrator. The ION shall include statements regarding: the cause of Non-compliance, actions taken to prevent any further non-compliance, environmental impact resulting from the non-compliance, and any actions taken to reduce the environmental impact from the non-compliance.

- A. If non-compliance occurs and an ION is not filed, the SITE is in violation of the LDEC PERMIT.

- B. Recurring non-compliance could be a violation of the LDEC PERMIT.

15.4 Notice of Violation

- A. If the ZONING ADMINISTRATOR finds any conditions not as stated in the application or approved plans, the ZONING ADMINISTRATOR may issue a Notice of Violation or a STOP-WORK ORDER on the entire project, or any specified part thereof, until a revised plan is submitted conforming to current SITE conditions. Failure to obtain a LDEC PERMIT for activities regulated under this Ordinance constitutes a violation.
- B. If the ZONING ADMINISTRATOR issues a Notice of Violation or a STOP-WORK ORDER on the entire project, or any specified part thereof, pursuant to a MAJOR LDEC PERMIT, the ZONING ADMINISTRATOR shall also notify the IEPA that the project may not be in compliance with the ILR10 permit.

15.5 Prevention of Hazard

Whenever the ZONING ADMINISTRATOR determines that any LAND DISTURBANCE on any private property is an imminent hazard to life and limb, or endangers the property of another, or adversely affects the safety, use, SLOPE, or SOIL stability of a public way, publicly controlled WETLAND, or WATERCOURSE, then the ZONING ADMINISTRATOR shall issue a Stop-Work Order and require that all LAND DISTURBANCE activities cease and the corrective work begin immediately.

15.6 Stop-Work Order

- A. The ZONING ADMINISTRATOR may require that, on a SITE, all work which is being performed contrary to the provisions of this Ordinance or is being performed in an unsafe or dangerous manner shall immediately stop.
- B. STOP-WORK ORDERS do not include work as is directed to be performed to remove a violation or dangerous or unsafe condition as provided in the STOP-WORK ORDER..
- C. The ZONING ADMINISTRATOR may issue a STOP-WORK ORDER for the entire project or any specified part thereof if any of the following conditions exist:
 - 1. Any LAND DISTURBANCE activity regulated under this Ordinance is being undertaken without a LDEC PERMIT.
 - 2. The ESCP or SWPPP is not being fully implemented.
 - 3. Any of the conditions of the LDEC PERMIT are not being met.
 - 4. The work is being performed in a dangerous or unsafe manner.
 - 5. Refusal to allow entry for inspection.
- D. A STOP-WORK ORDER shall be issued as follows:
 - 1. The STOP-WORK ORDER shall be in writing and shall be posted and served upon the OWNER and PERMITTEE, as provided below. In addition, a copy of the STOP-WORK ORDER may be given to any person in charge of or performing work on drainage improvements in the DEVELOPMENT, or to an agent of any of the foregoing.
 - 2. The STOP-WORK ORDER shall state the conditions under which work may be resumed.
 - 3. No person shall continue any work after having been served with a STOP-WORK ORDER.
 - 4. For the purposes of this section, a STOP-WORK ORDER is validly posted by posting a copy of the STOP-WORK ORDER on the SITE of the LAND DISTURBANCE in reasonable proximity to a location where the LAND DISTURBANCE is taking place. Additionally, in the case of work for which there is a LDEC PERMIT, a copy of the STOP-WORK ORDER, shall be mailed by first

class mail to the address listed by the PERMITTEE and in the case of work for which there is no LDEC PERMIT, a copy of the STOP-WORK ORDER shall be mailed to the person to whom real estate taxes are assessed, or if none, to the taxpayer shown by the records of the Supervisor of Assessment.

5. If the LAND DISTURBANCE continues more than 24 hours after the STOP-WORK ORDER is posted on the SITE, the ZONING ADMINISTRATOR may do the following:
 - a. If there is a LDEC PERMIT the ZONING ADMINISTRATOR may revoke the LDEC PERMIT
 - b. If there is no LDEC PERMIT, the ZONING ADMINISTRATOR may request the State's Attorney to obtain injunctive relief.
6. The ZONING ADMINISTRATOR may retract the revocation.
7. Ten (10) days after posting a STOP-WORK ORDER, the ZONING ADMINISTRATOR may issue a notice to the OWNER and/or PERMITTEE of the intent to perform the work necessary to minimize EROSION and institute SEDIMENT control. The ZONING ADMINISTRATOR or his/her designated representative may go on the land and commence work after fourteen (14) days from issuing the notice. The costs incurred to perform this work shall be paid by the OWNER or PERMITTEE. In the event no LDEC PERMIT was issued, the costs, plus a reasonable administrative fee, shall be billed to the OWNER.
8. Compliance with the provisions of this Ordinance may also be enforced by injunction.

15.7 Legal Proceedings

- A. A complaint may be filed with the Circuit Court for any violation of this Ordinance. A separate violation shall be deemed to have been committed on each day that the violation existed.
- B. In addition to other remedies, the State's Attorney may institute any action or proceeding which:
 1. Prevents the unlawful CONSTRUCTION, alteration, repair, maintenance, or removal of drainage improvements in violation of this Ordinance or the violation of any LDEC PERMIT issued under the provisions of this Ordinance.
 2. Prevents the occupancy of a building, STRUCTURE or land where such violation exists.
 3. Prevents any illegal act, conduct, business, or use in or about the land where such violation exists.
 4. Restrains, corrects or abates the violation.
- C. In any action or proceeding under this section, the State's Attorney may request the court to issue a restraining order or preliminary injunction, as well as a permanent injunction, upon such terms and conditions as will enforce the provisions of this Ordinance. A lien may also be placed on the property in the amount of the cleanup costs.

15.8 Penalties

- A. Penalties for violation of this Ordinance shall be governed by the requirements of this Ordinance and Section 10 of the Champaign County Zoning Ordinance. This Ordinance shall prevail where there is a conflict but the Zoning Ordinance shall prevail where this Ordinance is silent.
- B. Any person, firm, corporation or agency acting as principal, agent, employee or otherwise, who fails to comply with the provisions of this Ordinance shall be punishable

by a fine of not less than one hundred dollars (\$100.00) per day and not more than five hundred dollars (\$500.00) per day for each separate offense. Each day there is a violation of any part of this Ordinance shall constitute a separate offense.

16. RULES OF CONSTRUCTION

This Ordinance shall be construed liberally in the interests of the public so as to protect the public health, safety, and welfare.

17. APPEAL, WAIVER OR VARIANCE

- A. Any part here of or this entire Ordinance may be waived or varied by the by the relevant Approval Authority in accord with the relevant provision of Article 18 of the Champaign County Subdivision Regulations or Section 9.1.9 of the Champaign County Zoning Ordinance except for specific requirements of the ILR10.
- B. When the ZONING ADMINISTRATOR is the Approval Authority, the PERMITTEE, or its designee, may appeal a decision of the ZONING ADMINISRATOR pursuant to this Ordinance as authorized in Section 9.1.8 of the Zoning Ordinance. The filing of an appeal shall not operate as a stay of a Notice of Violation or STOP-WORK ORDER. The County shall grant the appeal and issue the appropriate instructions to the Department of Planning and Zoning upon a finding of fact that there is no violation of the Ordinance or the LDEC PERMIT issued.

18. EFFECTIVE DATE

This ordinance shall become effective upon adoption.

Appendix A: Adopting Resolution and Amendments

1. Ordinance No.962, Case 769-AT-13, adopted on June 19, 2015
2. Ordinance No. 963, Case 773-AT-13, adopted on June 19, 2015

Appendix B: Exempt Impervious Area

The following graph illustrates the impervious area exemption established in Subparagraph 8.2.A.5. The mathematical expressions for the different portions of the graph are also included. Exemption status can either be read directly from Subparagraph 8.2.A.5. or the graph or determined mathematically using the mathematical expressions.

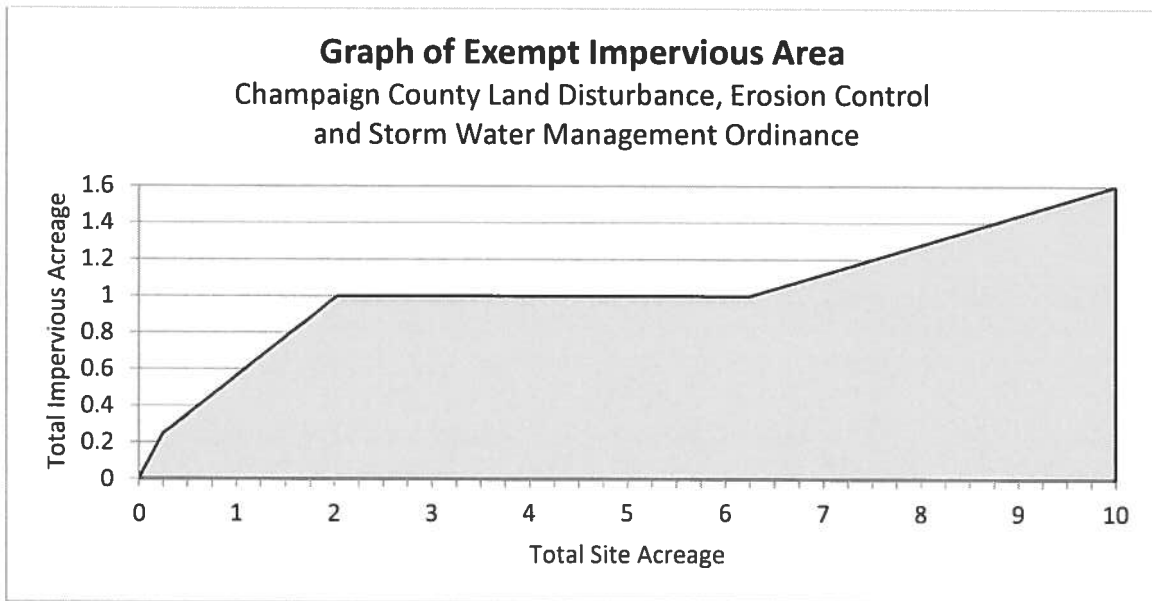

Mathematical Expressions for Exempt Impervious Area

Site Area	Project is Exempt if:
Less than or equal to 0.25 acres	Impervious Area is less than or equal to Site Area
Greater than 0.25 acres or equal to 2.0 acres	Impervious Area is less than or equal to 0.14 acres plus 0.423 x Site Area
Greater than 2.0 acres or equal to 6.25 acres	Impervious Area is less than or equal to 1.0 acres
Greater than 6.25 acres	Impervious Area is less than or equal to 0.16 x Site Area

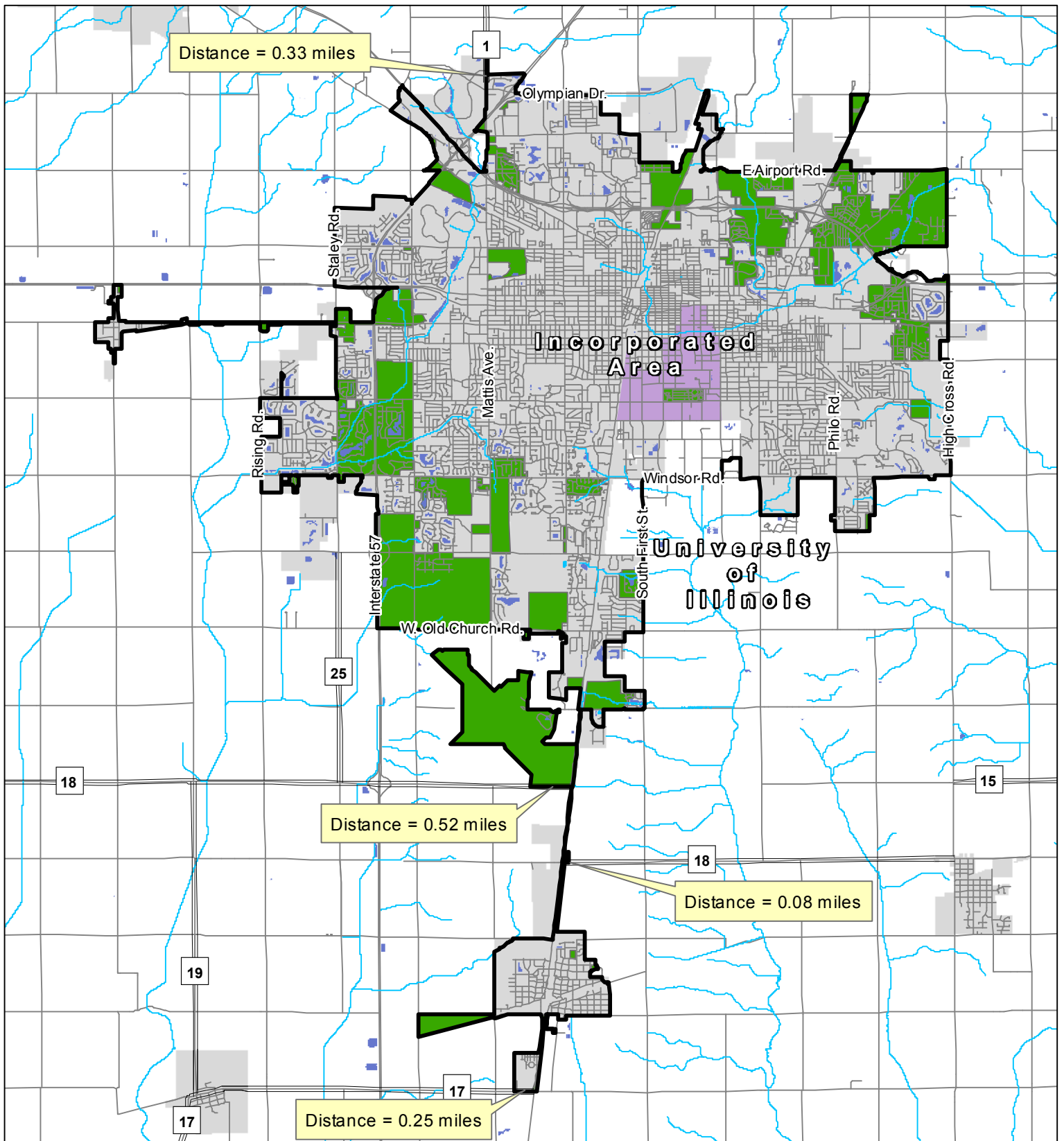



Champaign County MS4 Jurisdiction

Urbanized Area based on the 2010 Census

This map shows the defined MS4 jurisdiction including 10.4 square miles of unincorporated County. Location and size of County stormwater facilities are noted (Ex: Distance = 0.25 miles).

MS4 Related Boundaries

-  Streets
-  Urbanized Area 2010
-  County MS4 Area 2012



Map Created
7/17/14

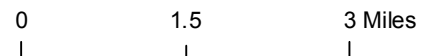

Appendix D

Technical Manual

Minor Land Disturbance Erosion Control Permit

Table of Contents

Erosion Control Practices Flow Chart.....	D-2
<u>Example Erosion and Sediment Control Plan #1. Grass already established and limited soil disturbance).....</u>	<u>D-3</u>
<u>Example Erosion and Sediment Control Plan #2. Grass not already established or all soil disturbed</u>	<u>D-4</u>
General Notes.....	D-5
Standard Details to be included from Appendix F (and label for noting on ESCP):	
Stabilized Lot Entrance Standard Detail (SD1)	
Perimeter Control: Silt Fence Standard Details (SD2)	
Perimeter Control: Grass Buffer Strip Standard Details (SD3)	
Inlet Protection: Inlet Filter Protector Standard Details (SD4)	
Concentrated Flow Control: Erosion Control Blanket Standard Details (SD5)	
Soil Stabilization (non-vegetative): Mulching (SD6)	
Vegetative Soil Stabilization: Sodding Standard Details (SD7)	
Vegetative Soil Stabilization: Permanent Seeding (SD8)	
Pump Discharge Filter Bag Standard Details (SD9)	
Concrete Washout Facilities Standard Details (SD10)	

(Note: Pamphlet versions of the Storm Water Management and Erosion Control Ordinance may be made available with only Appendix D or Appendix E and contain only the relevant details from Appendix F.)

Minor Land Disturbance Erosion Control Permit

EROSION CONTROL PRACTICES FLOW CHART

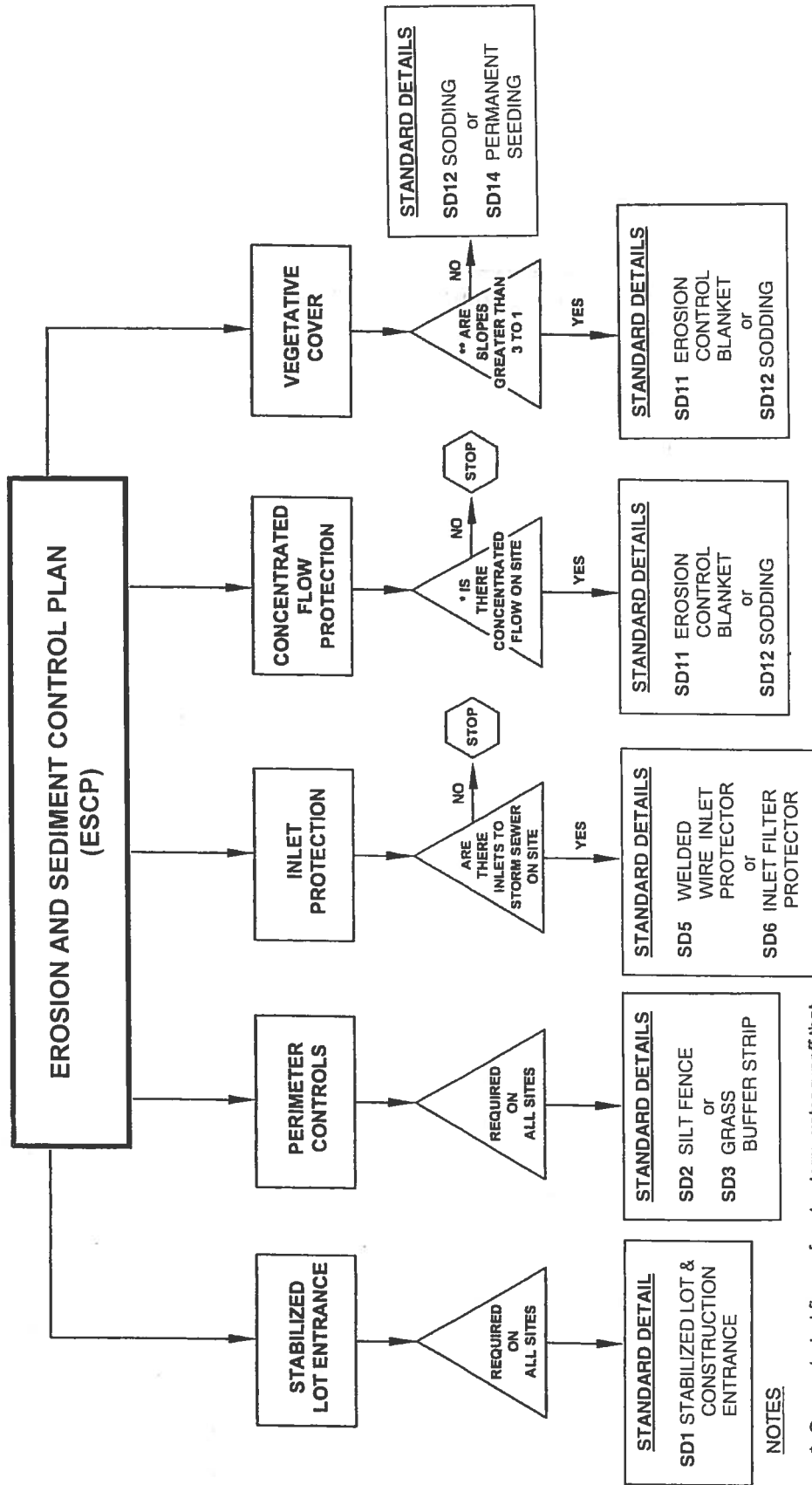

NOTES

* Concentrated flow refers to storm water runoff that has been concentrated and is flowing through small depressions, rills, gullies, ditches or swales.

** 3 to 1 refers to 3 feet horizontal to 1 foot vertical on slopes. 

Example Erosion and Sediment Control Plan (ESCP) for a New Home on a Typical Rural Lot in MS4 Area

Example 1: Grass already established - limited soil disturbance area

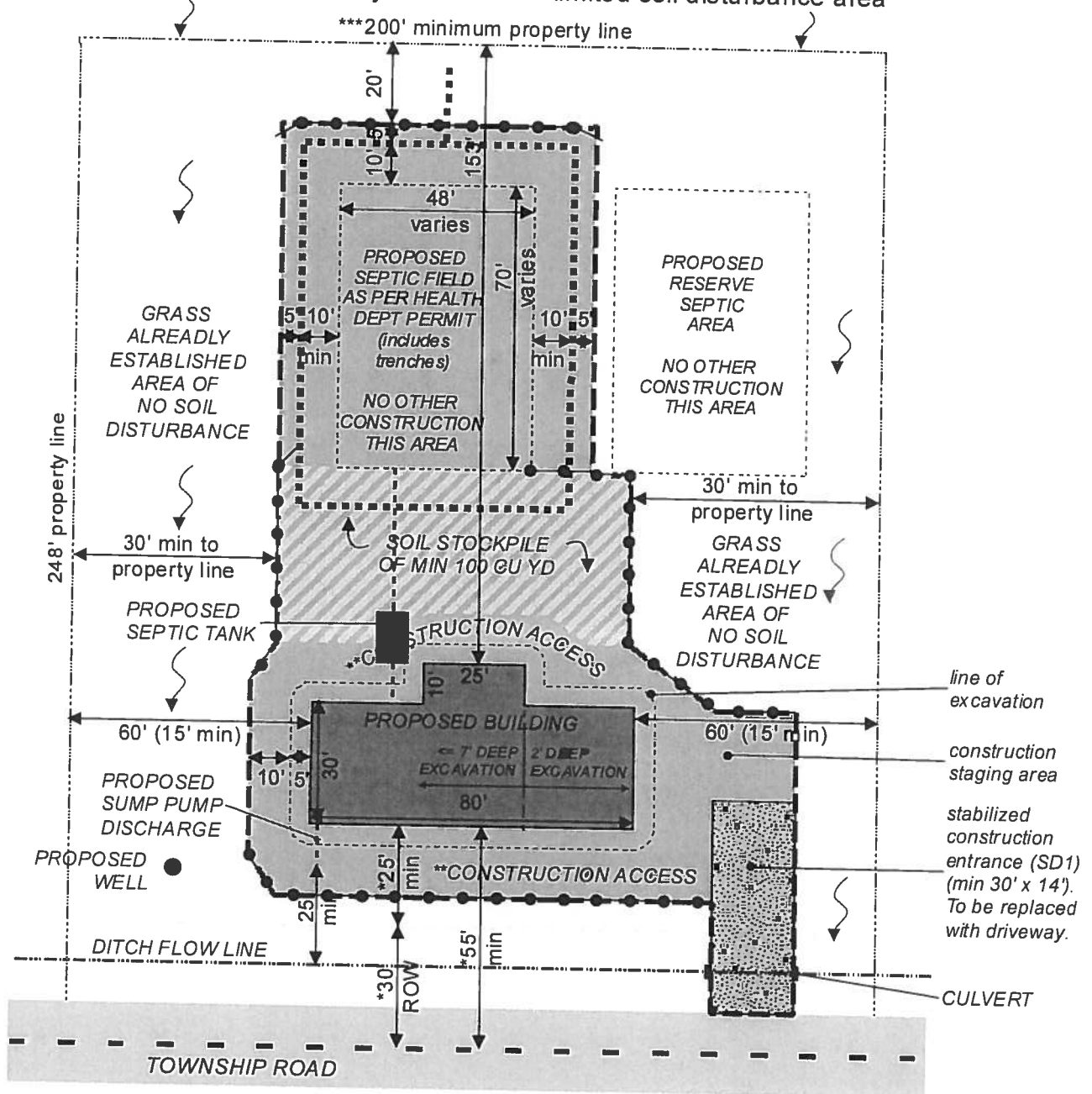

- * minimum setback varies depending on street classification
- ** construction access as required by contractor
- *** minimum lot width in AG-1 and CR Districts

Limit of soil disturbance (no construction activities or traffic outside this area); this area to receive permanent seeding (SD8) and mulching and/or sodding (SD12) upon construction completion



- Notes:
1. ESCP may be prepared on a photocopy of the Zoning Use Permit Site Plan provided by the Department of Planning & Zoning.
 2. For general construction sequence see General Notes in Technical Appendix D of the Stormwater Management and Erosion Control Ordinance
 3. SD1, SD2, SD 8 and SD 12 are Standard Details in Technical Appendix D of the Stormwater Management and Erosion Control Ordinance

Legend

- LIMIT OF SOIL DISTURBANCE (indicate by pencil shading or use of highlighter, etc.)
- SILT FENCE (SD2)
- Direction of Drainage

- Curtain Drain
- Septic Field
- Reserve Septic Field
- Stabilized Construction Entrance (SD1)

- Soil Stockpile Area
- Residence
- Property Line
- Township Road

Champaign County
Department of
PLANNING &
ZONING

DRAFT Dec 2011

Example Erosion and Sediment Control Plan (ESCP) for a New Home on a Typical Rural Lot in MS4 Area

Example 2: All soil disturbed on property

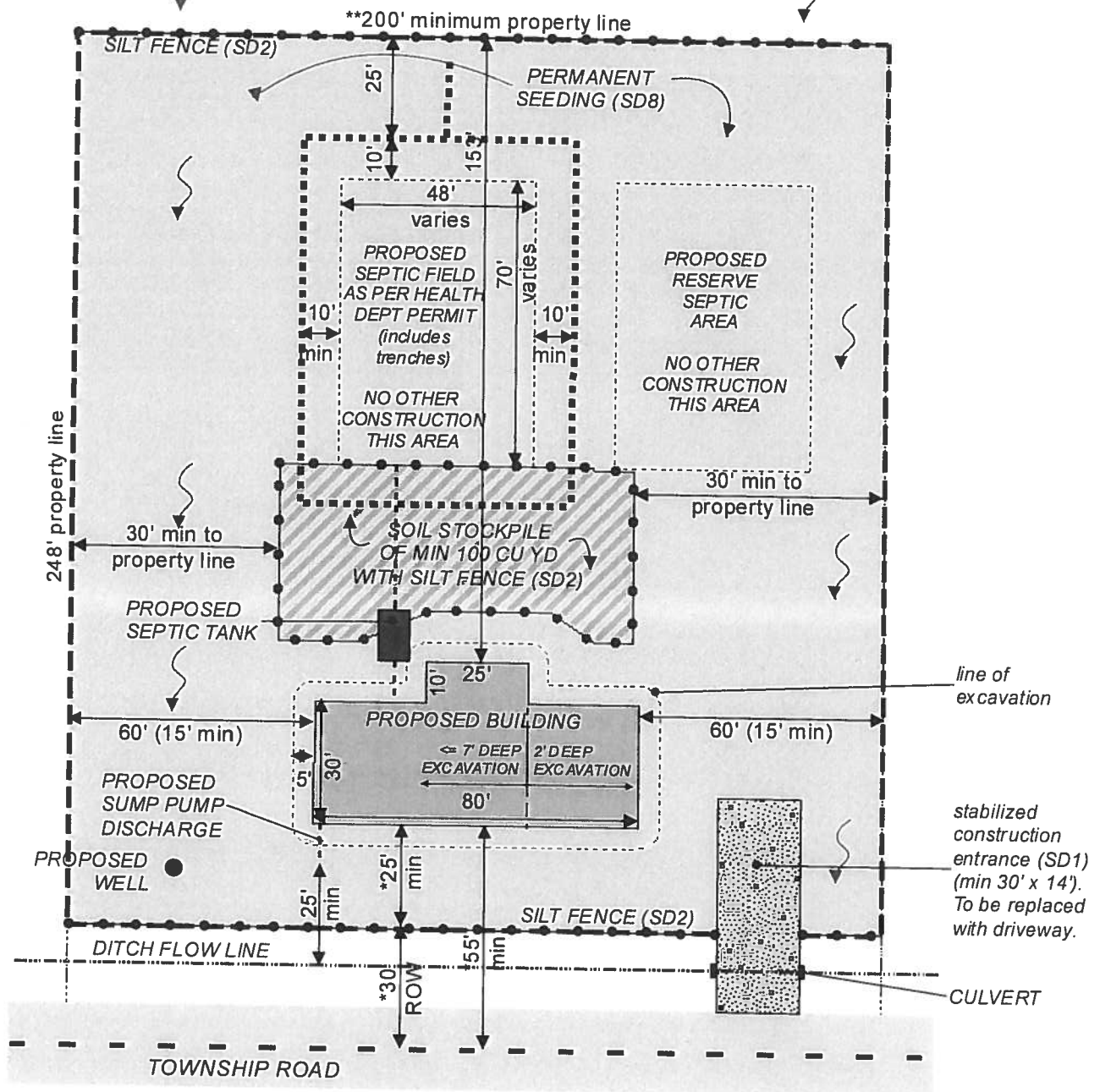

* minimum setback varies depending on street classification
 ** minimum lot width in AG-1 and CR Districts

Notes:

- ESCP may be prepared on a photocopy of the Zoning Use Permit Site Plan provided by the Department of Planning & Zoning.
- For general construction sequence see General Notes in Technical Appendix D of the Stormwater Management and Erosion Control Ordinance
- SD1, SD2, and SD8 are Standard Details in Technical Appendix D of the Stormwater Management and Erosion Control Ordinance



Legend

- LIMIT OF SOIL DISTURBANCE (indicate by pencil shading or use of highlighter, etc.)
- CURTAIN DRAIN
- SOIL STOCKPILE AREA
- SEPTIC FIELD
- RESIDENCE
- RESERVE SEPTIC FIELD
- STABILIZED CONSTRUCTION ENTRANCE (SD1)
- SILT FENCE (SD2)
- PROPERTY LINE
- TOWNSHIP ROAD
- DIRECTION OF DRAINAGE

NOTES ON INSTALLATION AND CONSTRUCTION SEQUENCE

1. Apply for both a Zoning Use Permit and a Land Disturbance Erosion Control (LDEC) Permit at the same time.
2. First, the LDEC Permit will be approved with the Erosion and Sediment Control Plan (ESCP) that authorizes installation of the following:
 - A. Install stabilized lot entrance for all construction access.
 - B. Install perimeter controls where storm water enters and leaves the site.
 - C. Call Zoning Administrator for inspection of perimeter controls.
3. Next, get written approval of stabilized lot entrance and perimeter controls from the Zoning Administrator before further construction.
4. The Zoning Use Permit can only be approved after approval of perimeter Controls. The Zoning Use Permit authorizes general construction and the proposed use. During general construction:
 - A. Follow the approved ESCP.
 - B. Ensure that any stockpile is indicated on the ESCP and that it meets the minimum separation requirements.
 - C. Inspect, Maintain and Repair all erosion and sedimentation controls (especially perimeter controls) during construction until Final Stabilization is achieved.
 - D. Call the Zoning Administrator to request a Zoning Compliance Inspection when construction is complete.
5. Final Stabilization is a uniform perennial vegetative land cover of at least 70% density and cannot be achieved until there is no more land disturbance. Regarding Final Stabilization:
 - A. Final Stabilization may be completed by either the homebuilder or the homeowner but must be completed within two years of approval of the LDEC Permit.
 - B. When Final Stabilization is achieved submit a Letter of Termination to the Zoning Administrator who will inspect the Final Stabilization.
 - C. Perimeter controls should be removed (carefully) after Final Stabilization is inspected and approved in writing by the Zoning Administrator.

NOTES ON CONCENTRATED FLOWS

1. Install erosion control blanket (SD5) or sod (SD7) for concentrated flow areas.
2. Provide soil protection and energy dissipation at **gutter downspouts** or **roof edge drip line** to protect soil at all times but especially during establishment of final ground cover. Examples of soil protection and energy dissipation are erosion control blanket (SD5) or sod (SD7).
3. Provide inlet protection (SD4) at all storm sewer inlets, grates, drains, and manholes that are in proximity of disturbed area. Contact relevant authority (highway commissioner or relevant utility) prior to installation.

Appendix E

Technical Manual

Major Land Disturbance Erosion Control Permit

Table of Contents

Erosion Control Practices Flow Chart.....	E-3
Supplemental Land Disturbance Erosion Control Permit Application Form.....	E-4
Erosion and Sediment Control Plan Checklist.....	E-5
Sample Permit Plan for Major Land Disturbance Erosion Control Permit.....	E-9

Other Standard Forms:

Illinois Environmental Protection Agency ILR10 Notice of Intent (NOI) Form w/
Instructions

Illinois Department of Transportation Contractor Certification Statement

Illinois Environmental Protection Agency ILR10 Construction Site Storm Water
Discharge Incidence of Non-Compliance (ION) Form w/ Guidelines

Illinois Environmental Protection Agency ILR10 Notice of Termination (NOT) Form w/
Guidelines

Illinois Department of Transportation Storm Water Pollution Prevention Plan Erosion
Control Inspection Report Form

Illinois Department of Transportation Storm Water Pollution Prevention Plan (SWPPP)
Form (Note: Under item II.E.1. the technical basis for selection of permanent storm
water management controls should be the Champaign County Storm Water Management
and Erosion Control Ordinance.)

Standard Details to be included from Appendix F:

Stabilized Construction Entrance Standard Details

Perimeter Control: Silt Fence Standard Details

Perimeter Control: Grass Buffer Strip Standard Details

Perimeter Control: Super Silt Fence Standard Details

Inlet Protection: Welded Wire Inlet Protection Standard Details

Inlet Protection: Inlet Filter Protector Standard Details

Concentrated Flow Control: Rock Check Dam Standard Details

Concentrated Flow Control: Triangular Silt Dike Standard Details

Concentrated Flow Control: Diversion Berm Standard Details

Concentrated Flow Control: Turf Reinforcement Mat Standard Details

Standard Details to be included from Appendix F (continued):

Concentrated Flow Control: Erosion Control Blanket Standard Details

Soil Stabilization (non-vegetative): Mulching

Vegetative Soil Stabilization: Sodding Standard Details

Vegetative Soil Stabilization: Permanent Seeding

Pump Discharge Filter Bag Standard Details

Concrete Washout Facilities Standard Details

(Note: Pamphlet versions of the Storm Water Management and Erosion Control Ordinance may be made available with only Appendix D or Appendix E and therein contain only the relevant details from Appendix F.)

Major Land Disturbance Erosion Control Permit EROSION CONTROL PRACTICES FLOW CHART

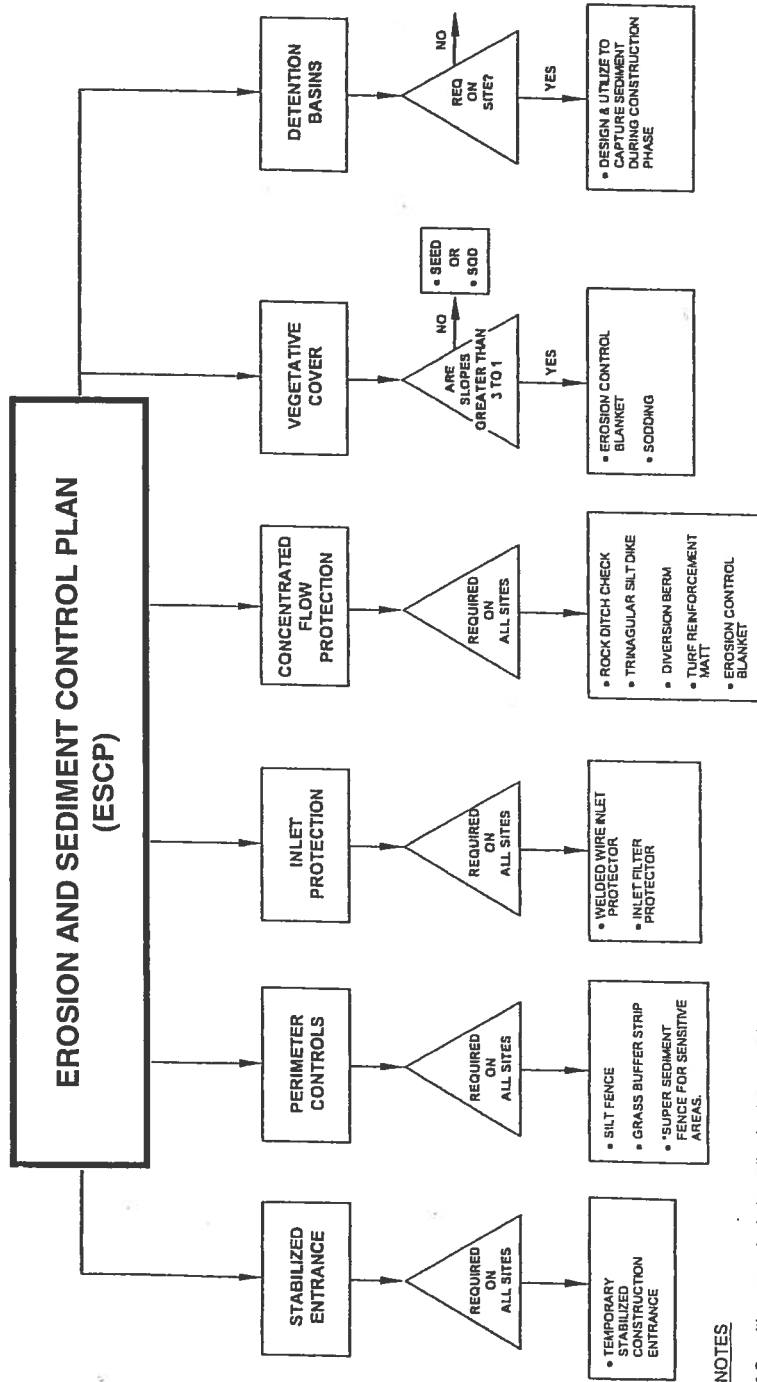

NOTES

- Sensitive areas include wetlands, rivers, creeks, natural areas, and other areas designated

Champaign County Land Disturbance Erosion Control and Storm Water Management Ordinance
Technical Appendix E

Supplemental Land Disturbance Erosion Control Permit Application Form
Major Land Disturbance Erosion Control Permit

14. ILR-10 Permit Number _____

Attach copies of the following documents submitted to the IEPA for compliance with ILR-10:

- Notice of Intent (NOI)
- Storm Water Pollution Prevention Plan (SWPPP)

Also provide Champaign County with copies of all IEPA documents required for compliance with ILR-10.

15. Name and Telephone Number of Onsite Responsible Person

Name: _____

Company: _____

Telephone Number: _____

I (we) affirm that the above information is accurate and that I (we) shall conduct the above described land disturbance in accordance with Part 91 Soil Erosion and Sedimentation Control, of the Natural Resource and Environmental Protection Act, 1994 PA No. 451 as amended, and all applicable local ordinances and the documents accompanying this application.

Landowner's Signature	Print Landowner Name	Date
-----------------------	----------------------	------

Designated Agent's Signature	Print Agent Name	Date
------------------------------	------------------	------

16. Complete the following checklist and include the drawings, specifications, and supporting documentation with the completed Land Use Permit Application.

EROSION AND SEDIMENT CONTROL PLAN CHECKLIST

Project: _____

- | | <u>Sheet/Page No.</u> |
|--|--------------------------------|
| I. Project Narrative Description | |
| A. Description of proposed development | <input type="checkbox"/> _____ |
| B. Past, present and proposed land uses including adjacent properties | <input type="checkbox"/> _____ |
| C. Surface area involved, use of excess spoil material, use of borrow material | <input type="checkbox"/> _____ |
| II. Vicinity Map – 500 ft around site | |
| A. 8½" x 11" copy of a USGS map with the outline of the project area. | <input type="checkbox"/> _____ |
| B. Scale indicated on map | <input type="checkbox"/> _____ |
| C. Streets and significant structures properly labeled on map. | <input type="checkbox"/> _____ |
| D. Watercourses, water bodies, wetlands, and other significant geographic features in the vicinity of the project area properly identified and labeled on the maps | <input type="checkbox"/> _____ |
| III. Site Drawing(s) | |
| A. Sealed by licensed professional engineer | <input type="checkbox"/> _____ |
| B. Existing and proposed contours shown and labeled -100 ft around site. | <input type="checkbox"/> _____ |
| C. Property lines shown and labeled | <input type="checkbox"/> _____ |

- D. Scale, legend, and north arrow shown and labeled. _____
- E. 100 year flood elevation and floodplain delineation shown and labeled _____
- F. Delineation of any wetlands, natural or artificial water storage detention areas, and drainage ditches on the site. _____
- G. Delineation of any storm drainage systems including quantities of flow and site conditions around all points of surface water discharge from the site. . . . _____
- H. Delineation of any areas of vegetation or trees to be preserved _____
- I. Delineation of any grading or land disturbance activity including specific limits of disturbance and stockpile locations _____
- J. Stabilized construction entrance provisions shown and labeled _____
- K. Perimeter erosion control provisions shown and labeled _____
 - Silt Fence
 - Grass Buffer Strip
 - Super Sediment Fence for Sensitive Areas
- L. Inlet protection provisions shown and labeled _____
 - Stone Bags
 - Welded Wire Inlet Protectors
 - Approved Manufacturers Product
- M. Concentrated flow provisions shown and labeled _____
 - Diversion Berms
 - Erosion Control Blanket
 - Turf Reinforcement Matt
 - Stone Ditch Check

- N. Vegetative restoration provisions shown and labeled _____
- Seed
 - Erosion Control Blanket
 - Sod

- O. Sediment traps or basins shown and labeled _____

- P. Plan note stating "Following initial soil disturbance or redisturbance, permanent or temporary stabilization shall be completed within seven (7) calendar days on all perimeter dikes, swales, ditches, perimeter slopes, and all slopes greater than 3 horizontal to 1 vertical (3:1); embankments of ponds, basins, and traps; and within fourteen (14) days on all other disturbed or graded areas. The requirements of this section do not apply to those areas which are shown on the plan and are currently being used for material storage or for those areas on which actual construction activities are currently being performed." _____

- Q. Erosion control provision details in accordance with standards presented in the Manual of Practice. _____

IV. Chronological Construction Schedule and Time Frame including the following:

- A. Clearing and grubbing those areas necessary for installation of perimeter erosion control devices _____
- B. Construction of perimeter erosion control devices _____
- C. Remaining interior site clearing and grubbing. _____
- D. Installation of permanent and temporary stabilization measures. _____
- E. Road grading _____
- F. Grading for remainder of the site _____
- G. Building, parking lot, and site construction _____

- H. Final grading, landscaping, or stabilization _____
- I. Implementation and maintenance of final erosion control structures _____
- J. Removal of temporary erosion control devices _____

V. Specifications

- A. Sediment retention structure specifications _____
- B. Surface runoff and erosion control devices specifications _____

VI. Vegetative Measures

- A. Description of vegetative measures _____
- B. Proposed vegetative conditions of the site on the 15th of each month between and including the months of April through October _____

VII. Concrete Washout Facilities

- A. Location of Concrete Washout Facility shown on Site Plan _____
- B. Details of Concrete Washout Facility _____

SAMPLE PERMIT PLAN

TYPICAL EROSION CONTROL PLAN ELEMENTS

- ① SUPER SEDIMENT FENCE TO PROTECT SENSITIVE AREAS.
- ② STABILIZED CONSTRUCTION ENTRANCES.
- ③ STABILIZE PARKING AND LAY DOWN AREA WITH GRAVEL PAD AND SILT FENCE AROUND DOWNHILL SIDES.
- ④ BUILD DETENTION PONDS AND SEDIMENT TRAPS
- ⑤ DIVERT UPSTREAM SITE WATER AROUND SITE WITH DIVERSION BERMS
- ⑥ PROTECT STOCKPILE WITH TEMPORARY VEGETATION AND SILT FENCE.
- ⑦ INLET PROTECTION ONCE STORM SEWERS ARE IN PLACE.
- ⑧ STABILIZE SOIL WITHIN 14 DAYS OF ROUGH GRADING WITH SOD, SEED BLANKETS, HYDRO MULCH, ETC.
- ⑨ SLOPES GREATER THAN 3:1 MUST RECEIVE EROSION CONTROL PROTECTION OF BLANKET OR SOD WITHIN 7 DAYS OF BEING PLACED OR STRIPPED.

LEGEND

— SILT FENCE OR OTHER LIKE CONTROL

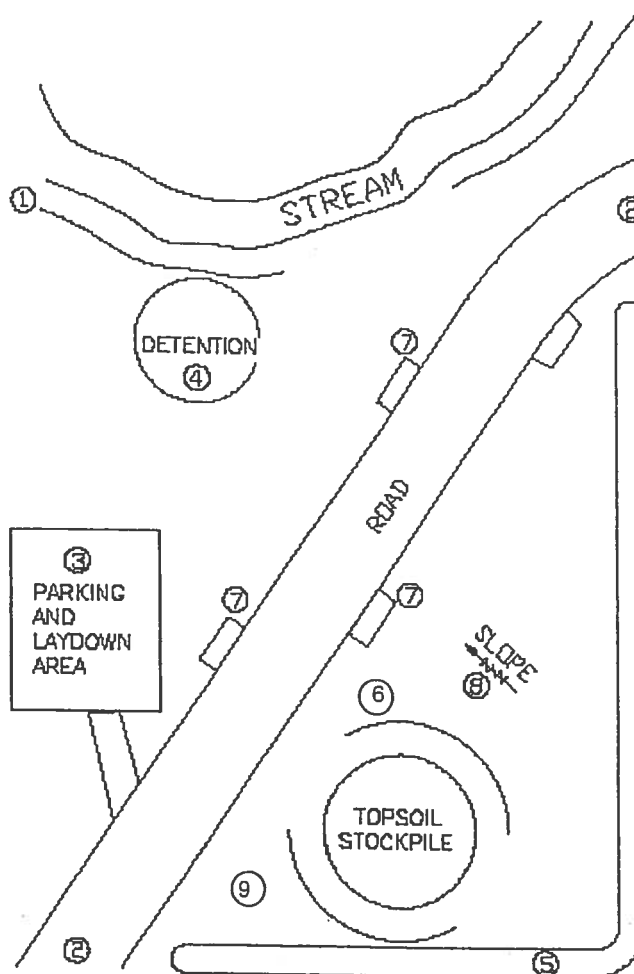



Illinois Environmental Protection Agency

Bureau of Water • 1021 North Grand Avenue East • P.O. Box 19276 • Springfield • Illinois • 62794-9276

Division of Water Pollution Control Notice of Intent (NOI) for General Permit to Discharge Storm Water Associated with Construction Site Activities

This fillable form may be completed online, a copy saved locally, printed and signed before it is submitted to the Permit Section at the above address.

For Office Use Only

OWNER INFORMATION

Permit No. ILR10 _____

Company/Owner Name: _____
Mailing Address: _____ Phone: _____
City: _____ State: _____ Zip: _____ Fax: _____
Contact Person: _____ E-mail: _____
Owner Type (select one) _____

CONTRACTOR INFORMATION

MS4 Community: Yes No

Contractor Name: _____
Mailing Address: _____ Phone: _____
City: _____ State: _____ Zip: _____ Fax: _____

CONSTRUCTION SITE INFORMATION

Select One: New Change of information for: ILR10 _____
Project Name: _____ County: _____
Street Address: _____ City: _____ IL Zip: _____
Latitude: _____ Longitude: _____
(Deg) (Min) (Sec) (Deg) (Min) (Sec) Section Township Range
Approximate Construction Start Date _____ Approximate Construction End Date _____

Total size of construction site in acres: _____
If less than 1 acre, is the site part of a larger common plan of development?
 Yes No

Fee Schedule for Construction Sites:
Less than 5 acres - \$250
5 or more acres - \$750

STORM WATER POLLUTION PREVENTION PLAN (SWPPP)

Has the SWPPP been submitted to the Agency? Yes No

(Submit SWPPP electronically to: epa.constilr10swppp@illinois.gov)

Location of SWPPP for viewing: Address: _____ City: _____

SWPPP contact information: _____ Inspector qualifications: _____

Contact Name: _____

Phone: _____ Fax: _____ E-mail: _____

Project inspector, if different from above _____ Inspector qualifications: _____

Inspector's Name: _____

Phone: _____ Fax: _____ E-mail: _____

TYPE OF CONSTRUCTION (select one)

Construction Type _____

SIC Code: _____

Type a detailed description of the project:

HISTORIC PRESERVATION AND ENDANGERED SPECIES COMPLIANCE

Has the project been submitted to the following state agencies to satisfy applicable requirements for compliance with Illinois law on:

Historic Preservation Agency Yes No

Endangered Species Yes No

RECEIVING WATER INFORMATION

Does your storm water discharge directly to: Waters of the State or Storm Sewer

Owner of storm sewer system: _____

Name of closest receiving water body to which you discharge: _____

Mail completed form to: Illinois Environmental Protection Agency
Division of Water Pollution Control
Attn: Permit Section
Post Office Box 19276
Springfield, Illinois 62794-9276
or call (217) 782-0610
FAX: (217) 782-9891

Or submit electronically to: epa.constilr10swppp@illinois.gov

I certify under penalty of law that this document and all attachments were prepared under my direction and supervision in accordance with a system designed to assure that qualified personnel properly gather and evaluate the information submitted. Based on my inquiry of the person or persons who manage this system, or those persons directly responsible for gathering the information, the information submitted is, to the best of my knowledge and belief, true, accurate, and complete. I am aware that there are significant penalties for submitting false information, including the possibility of fine and imprisonment. In addition, I certify that the provisions of the permit, including the development and implementation of a storm water pollution prevention plan and a monitoring program plan, will be complied with.

Any person who knowingly makes a false, fictitious, or fraudulent material statement, orally or in writing, to the Illinois EPA commits a Class 4 felony. A second or subsequent offense after conviction is a Class 3 felony. (415 ILCS 5/44(h))

Owner Signature:

Date:

Printed Name:

Title:

INSTRUCTIONS FOR COMPLETION OF CONSTRUCTION ACTIVITY NOTICE OF INTENT (NOI) FORM

Submit original, electronic or facsimile copies. Facsimile and/or electronic copies should be followed-up with submission of an original signature copy as soon as possible. Please write "copy" under the "For Office Use Only" box in the upper right hand corner of the first page.

This fillable form may be completed online, a copy saved locally, printed and signed before it is submitted to the Permit Section at:

Illinois Environmental Protection Agency
 Division of Water Pollution Control
 Permit Section
 Post Office Box 19276
 Springfield, Illinois 62794-9276
 or call (217) 782-0610
 FAX: (217) 782-9891

Or submit electronically to: epa.constilr10swppp@illinois.gov

Reports must be typed or printed legibly and signed.

Any facility that is not presently covered by the General NPDES Permit for Storm Water Discharges From Construction Site Activities is considered a new facility.

If this is a change in your facility information, renewal, etc., please fill in your permit number on the appropriate line, changes of information or permit renewal notifications do not require a fee.

NOTE: FACILITY LOCATION IS NOT NECESSARILY THE FACILITY MAILING ADDRESS, BUT SHOULD DESCRIBE WHERE THE FACILITY IS LOCATED.

Use the formats given in the following examples for correct form completion.

	Example	Format
Section	12	1 or 2 numerical digits
Township	12N	1 or 2 numerical digits followed by "N" or "S"
Range	12W	1 or 2 numerical digits followed by "E" or "W"

For the Name of Closest Receiving Waters, do not use terms such as ditch or channel. For unnamed tributaries, use terms which include at least a named main tributary such as "Unnamed Tributary to Sugar Creek to Sangamon River."

Submission of initial fee and an electronic submission of Storm Water Pollution Prevention Plan (SWPPP) for Initial Permit prior to the Notice of Intent being considered complete for coverage by the ILR10 General Permits. Please make checks payable to: Illinois EPA at the above address.

Construction sites with less than 5 acres of land disturbance - fee is \$250.

Construction sites with 5 or more acres of land disturbance - fee is \$750.

SWPPP should be submitted electronically to: epa.constilr10swppp@illinois.gov When submitting electronically, use Project Name and City as indicated on NOI form.



Prior to conducting any professional services at the site covered by this contract, the Contractor and every subcontractor must complete and return to the Resident Engineer the following certification. A separate certification must be submitted by each firm. Attach to this certification all items required by Section II.G of the Storm Water Pollution Prevention Plan (SWPPP) which will be handled by the Contractor/subcontractor completing this form.

Route _____	Marked Rte. _____
Section _____	Project No. _____
County _____	Contract No. _____

This certification statement is a part of SWPPP for the project described above, in accordance with the General NPDES Permit No. ILR10 issued by the Illinois Environmental Protection Agency.

I certify under penalty of law that I understand the terms of the Permit No. ILR 10 that authorizes the storm water discharges associated with industrial activity from the construction site identified as part of this certification.

In addition, I have read and understand all of the information and requirements stated in SWPPP for the above mentioned project; I have received copies of all appropriate maintenance procedures; and, I have provided all documentation required to be in compliance with the Permit ILR10 and SWPPP and will provide timely updates to these documents as necessary.

Contractor

Sub-Contractor

Print Name

Title

Name of Firm

Street Address

Signature

Date

Telephone

City/State/ZIP

Items which this Contractor/subcontractor will be responsible for as required in Section II.G. of SWPPP:



Illinois Environmental Protection Agency

Bureau of Water • 1021 N. Grand Avenue E. • P.O. Box 19276 • Springfield • Illinois • 62794-9276

Division of Water Pollution Control

Construction Site Storm Water Discharge Incidence of Non-Compliance (ION)

This fillable form may be completed online, a copy saved locally, printed and signed before it is submitted to the Compliance Assurance Section at the above address. You may email this completed form to: epa.swnoncomp@illinois.gov

Permittee Information:

For Office Use Only
Permit No. ILR10_____

Name: _____
 Street Address: _____ P.O. Box: _____
 City: _____ State: IL Zip Code: _____ County: _____
 Phone: _____ Email: _____

Construction Site Information:

Site Name: _____
 Street Address: _____
 City: _____ State: IL Zip Code: _____
 Latitude: _____ Longitude: _____
 (Deg) (Min) (Sec) (Deg) (Min) (Sec) Section Township Range

Cause of Non-Compliance

Actions Taken to Prevent Any Further Non-Compliance

Environmental Impact Resulting From the Non-Compliance

Actions Taken to Reduce the Environmental Impact Resulting From the Non-Compliance

Any person who knowingly makes a false, fictitious, or fraudulent material statement, orally or in writing, to the Illinois EPA commits a Class 4 felony. A second or subsequent offense after conviction is a Class 3 felony. (415 ILCS 5/44(h))

Owner Signature: _____

Date: _____

Printed Name: _____

Title: _____

DIVISION OF WATER POLLUTION CONTROL
ILLINOIS ENVIRONMENTAL PROTECTION AGENCY
FIELD OPERATIONS SECTION

GUIDELINES FOR COMPLETION OF INCIDENCE OF NON-COMPLIANCE (ION) FORM

Complete and submit this form for any violation of the Storm Water Pollution Prevention Plan observed during any inspection conducted, including those not required by the SWPPP. Please adhere to the following guidelines:

Initial submission within 24 hours by email, telephone or fax (see region fax numbers) of any incidence of non-compliance for any violation. Submit email copy to: epa.swnoncomp@illinois.gov. After 24 hours notification, submit signed original ION within 5 days to the following address:

Illinois Environmental Protection Agency
Division of Water Pollution Control
Compliance Assurance #19
Post Office Box 19276
Springfield, Illinois 62794-9276

FIELD OPERATIONS HEADQUARTERS
Bruce Yurdin, Manager
Phone: 217/782-3362 Fax: 217/785-1225
EMAIL: epa.swnoncomp@illinois.gov

Region 1 - ROCKFORD
Chuck Corley, Manager
Phone: 815/987-7760 Fax: 815/987-7005

Region 2 - DESPLAINES
Jay Patel, Manager
Phone: 847/294-4000 Fax: 847/294-4058

Region 3 - PEORIA
Jim Kammueler, Manager
Phone: 309/693-5463 Fax: 309/693-5467

Region 4 - CHAMPAIGN
Joe Koronkowski, Manager
Phone: 217/278-5800 Fax: 217/278-5808

Region 5 - SPRINGFIELD
Bruce Yurdin, FOS Manager
Phone: 217/782-3362 Fax: 217/785-1225

Region 6 - COLLINSVILLE
Bruce Yurdin, FOS Manager
Phone: 217/782-3362 Fax: 217/785-1225

Region 7 - MARION
Byron Marks, Manager
Phone: 618/993-7200 Fax: 618/997-5467

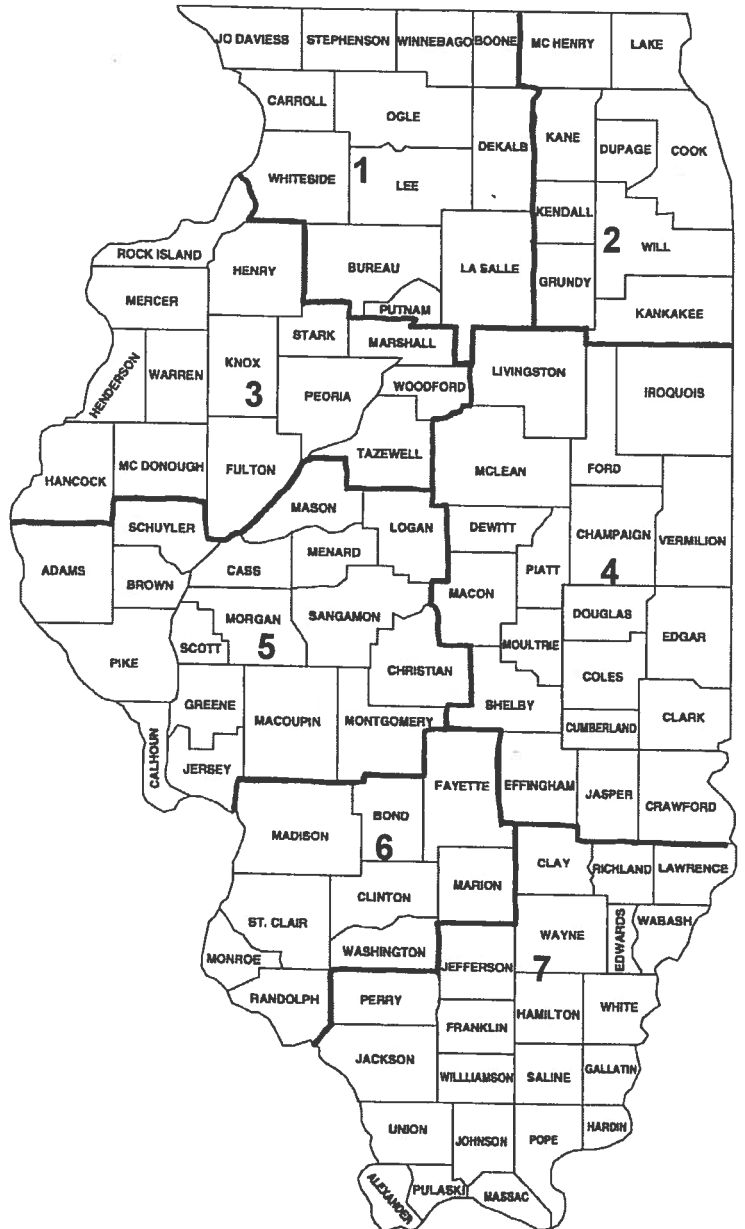



Illinois Environmental Protection Agency

Bureau of Water • 1021 North Grand Avenue East • P.O. Box 19276 • Springfield • Illinois • 62794-9276

Division of Water Pollution Control NOTICE OF TERMINATION (NOT) of Coverage under the General Permit for Storm Water Discharges Associated with Construction Site Activities

This fillable form may be completed online, a copy saved locally, printed and signed before it is submitted to the Permit Section at the above address.

OWNER INFORMATION

Permit No. ILR10 _____

Owner Name: _____

Owner Type (select one) _____

Mailing Address: _____ Phone: _____

City: _____ State: _____ Zip: _____ Fax: _____

Contact Person: _____ E-mail: _____

CONTRACTOR INFORMATION

Contractor Name: _____

Mailing Address: _____ Phone: _____

City: _____ State: _____ Zip: _____ Fax: _____

CONSTRUCTION SITE INFORMATION

Facility Name: _____

Street Address: _____

City: _____ IL Zip: _____ County: _____

NPDES Storm Water General Permit Number: ILR10 _____

Latitude: _____ Longitude: _____
(Deg) (Min) (Sec) (Deg) (Min) (Sec) Section Township Range

DATE PROJECT HAS BEEN COMPLETED AND STABILIZED: _____

NOTE: Coverage under this permit cannot be terminated without the completion date.

I certify under penalty of law that disturbed soils at the identified facility have been finally stabilized or that all storm water discharges associated with industrial activity from the identified facility that are authorized by an NPDES general permit have otherwise been eliminated. I understand that by submitting this notice of termination, that I am no longer authorized to discharge storm water associated with industrial activity by the general permit, and that discharging pollutants in storm water associated with industrial activity to Waters of the State is unlawful under the Environmental Protection Act and the Clean Water Act where the discharge is not authorized by an NPDES Permit.

Any person who knowingly makes a false, fictitious, or fraudulent material statement, orally or in writing, to the Illinois EPA commits a Class 4 felony. A second or subsequent offense after conviction is a Class 3 felony. (415 ILCS 5/44(h))

Owner Signature: _____

Date: _____

Mail completed form to: Illinois Environmental Protection Agency
Division of Water Pollution Control, Attn: Permit Section
1021 North Grand Avenue East
P.O. Box 19276
Springfield, Illinois 62794-9276

(Do not submit additional documentation unless requested)

IL 532 2102 WPC 621 Rev 12/11 This Agency is authorized to require this information under Section 4 and Title X of the Environmental Protection Act (415 ILCS 5/4, 5/39). Failure to disclose this information may result in: a civil penalty of not to exceed \$50,000 for the violation and an additional civil penalty of not to exceed \$10,000 for each day during which the violation continues (415 ILCS 5/42) and may also prevent this form from being processed and could result in your application being denied. This form has been approved by the Forms Management Center.

GUIDELINES FOR COMPLETION OF NOTICE OF TERMINATION (NOT) FORM

Please adhere to the following guidelines:

Submit original, electronic or facsimile copies. Facsimile and/or electronic copies should be followed-up with submission of an original signature copy as soon as possible.

Submit completed forms to:

Illinois Environmental Protection Agency
 Division of Water Pollution Control, Attn: Permit Section
 1021 North Grand Avenue East
 P.O. Box 19276
 Springfield, Illinois 62794-9276
 or call (217) 782-0610
 FAX: (217) 782-9891

Or submit electronically to: epa.constilr10swppp@illinois.gov

Reports must be typed or printed legibly and signed.

NOTE: FACILITY LOCATION IS NOT NECESSARILY THE FACILITY MAILING ADDRESS, BUT SHOULD DESCRIBE WHERE THE FACILITY IS LOCATED.

Use the formats given in the following examples for correct form completion.

	Example	Format
Section	12	1 or 2 numerical digits
Township	12N	1 or 2 numerical digits followed by "N" or "S"
Range	12W	1 or 2 numerical digits followed by "E" or "W"

Final stabilization has occurred when:

- (a) all soil disturbing activities at the site have been completed;
- (b) a uniform perennial vegetative cover with a density of 70% of the native background vegetative cover for the area has been established on all unpaved areas not covered by permanent structures; or
- (c) equivalent permanent stabilization measures have been employed.



Date of Inspection: County: Name of Inspector: Section: Type of Inspection: Weekly [] >0.5" Precip. [] Precip. Amt: " District: Contractor: Contract No: Subs: Job No: Project: NPDES/ESC Deficiency Deduction: \$ NPDES Permit No: Total Disturbed Area: acre Ready for Final Cover: acre Final Cover Established: acre

Erosion and Sediment Control Practices

Table with 4 columns: Item # / BMP, Description, YES, NO, N/A. Contains 11 rows of inspection items such as Slopes, Ditches, Perimeter Erosion Barrier, etc.

General Site Maintenance Required of the Permit

Table with 4 columns: Item #, Description, YES, NO, N/A. Contains 1 row for Vehicle Tracking inspection.



Route _____
Section _____
County _____

Marked Rte. _____
Project No. _____
Contract No. _____

This plan has been prepared to comply with the provisions of the National Pollutant Discharge Elimination System (NPDES) Permit No. ILR10 (Permit ILR10), issued by the Illinois Environmental Protection Agency (IEPA) for storm water discharges from construction site activities.

I certify under penalty of law that this document and all attachments were prepared under my direction or supervision in accordance with a system designed to assure that qualified personnel properly gathered and evaluated the information submitted. Based on my inquiry of the person or persons who manage the system, or those persons directly responsible for gathering the information, the information submitted is, to the best of my knowledge and belief, true, accurate and complete. I am aware that there are significant penalties for submitting false information, including the possibility of fine and imprisonment for knowing violations.

Print Name

Title

Agency

Signature

Date

I. Site Description:

- A. Provide a description of the project location (include latitude and longitude):
- B. Provide a description of the construction activity which is the subject of this plan:
- C. Provide the estimated duration of this project:
- D. The total area of the construction site is estimated to be _____ acres.
The total area of the site estimated to be disturbed by excavation, grading or other activities is _____ acres.
- E. The following is a weighted average of the runoff coefficient for this project after construction activities are completed:
- F. List all soils found within project boundaries. Include map unit name, slope information, and erosivity:
- G. Provide an aerial extent of wetland acreage at the site:
- H. Provide a description of potentially erosive areas associated with this project:
- I. The following is a description of soil disturbing activities by stages, their locations, and their erosive factors (e.g. steepness of slopes, length of slopes, etc):

- J. See the erosion control plans and/or drainage plans for this contract for information regarding drainage patterns, approximate slopes anticipated before and after major grading activities, locations where vehicles enter or exit the site and controls to prevent offsite sediment tracking (to be added after contractor identifies locations), areas of soil disturbance, the location of major structural and non-structural controls identified in the plan, the location of areas where stabilization practices are expected to occur, surface waters (including wetlands) and locations where storm water is discharged to surface water including wetlands.
- K. Identify who owns the drainage system (municipality or agency) this project will drain into:
- L. The following is a list of General NPDES ILR40 permittees within whose reporting jurisdiction this project is located.
- M. The following is a list of receiving water(s) and the ultimate receiving water(s) for this site. The location of the receiving waters can be found on the erosion and sediment control plans:
- N. Describe areas of the site that are to be protected or remain undisturbed. These areas may include steep slopes, highly erodible soils, streams, stream buffers, specimen trees, natural vegetation, nature preserves, etc.
- O. The following sensitive environmental resources are associated with this project, and may have the potential to be impacted by the proposed development:
- Floodplain
 - Wetland Riparian
 - Threatened and Endangered Species
 - Historic Preservation
 - 303(d) Listed receiving waters for suspended solids, turbidity, or siltation
 - Receiving waters with Total Maximum Daily Load (TMDL) for sediment, total suspended solids, turbidity or siltation
 - Applicable Federal, Tribal, State or Local Programs
 - Other
1. 303(d) Listed receiving waters (fill out this section if checked above):
- a. The name(s) of the listed water body, and identification of all pollutants causing impairment:
 - b. Provide a description of how erosion and sediment control practices will prevent a discharge of sediment resulting from a storm event equal to or greater than a twenty-five (25) year, twenty-four (24) hour rainfall event:
 - c. Provide a description of the location(s) of direct discharge from the project site to the 303(d) water body:
 - d. Provide a description of the location(s) of any dewatering discharges to the MS4 and/or water body:
2. TMDL (fill out this section if checked above)
- a. The name(s) of the listed water body:

- b. Provide a description of the erosion and sediment control strategy that will be incorporated into the site design that is consistent with the assumptions and requirements of the TMDL:
- c. If a specific numeric waste load allocation has been established that would apply to the project's discharges, provide a description of the necessary steps to meet that allocation:

P. The following pollutants of concern will be associated with this construction project:

- | | |
|--|---|
| <input type="checkbox"/> Soil Sediment | <input type="checkbox"/> Petroleum (gas, diesel, oil, kerosene, hydraulic oil / fluids) |
| <input type="checkbox"/> Concrete | <input type="checkbox"/> Antifreeze / Coolants |
| <input type="checkbox"/> Concrete Truck Waste | <input type="checkbox"/> Waste water from cleaning construction equipment |
| <input type="checkbox"/> Concrete Curing Compounds | <input type="checkbox"/> Other (specify) |
| <input type="checkbox"/> Solid Waste Debris | <input type="checkbox"/> Other (specify) |
| <input type="checkbox"/> Paints | <input type="checkbox"/> Other (specify) |
| <input type="checkbox"/> Solvents | <input type="checkbox"/> Other (specify) |
| <input type="checkbox"/> Fertilizers / Pesticides | <input type="checkbox"/> Other (specify) |

II. Controls:

This section of the plan addresses the controls that will be implemented for each of the major construction activities described in I.C. above and for all use areas, borrow sites, and waste sites. For each measure discussed, the Contractor will be responsible for its implementation as indicated. The Contractor shall provide to the Resident Engineer a plan for the implementation of the measures indicated. The Contractor, and subcontractors, will notify the Resident Engineer of any proposed changes, maintenance, or modifications to keep construction activities compliant with the Permit ILR10. Each such Contractor has signed the required certification on forms which are attached to, and are a part of, this plan:

A. **Erosion and Sediment Controls:** At a minimum, controls must be coordinated, installed and maintained to:

1. Minimize the amount of soil exposed during construction activity;
2. Minimize the disturbance of steep slopes;
3. Maintain natural buffers around surface waters, direct storm water to vegetated areas to increase sediment removal and maximize storm water infiltration, unless infeasible;
4. Minimize soil compaction and, unless infeasible, preserve topsoil.

B. **Stabilization Practices:** Provided below is a description of interim and permanent stabilization practices, including site-specific scheduling of the implementation of the practices. Site plans will ensure that existing vegetation is preserved where attainable and disturbed portions of the site will be stabilized. Stabilization practices may include but are not limited to: temporary seeding, permanent seeding, mulching, geotextiles, sodding, vegetative buffer strips, protection of trees, preservation of mature vegetation, and other appropriate measures. Except as provided below in II(B)(1) and II(B)(2), stabilization measures shall be initiated **immediately** where construction activities have temporarily or permanently ceased, but in no case more than **one (1) day** after the construction activity in that portion of the site has temporarily or permanently ceases on all disturbed portions of the site where construction will not occur for a period of fourteen (14) or more calendar days.

1. Where the initiation of stabilization measures is precluded by snow cover, stabilization measures shall be initiated as soon as practicable.
2. On areas where construction activity has temporarily ceased and will resume after fourteen (14) days, a temporary stabilization method can be used.

The following stabilization practices will be used for this project:

- | | |
|--|---|
| <input type="checkbox"/> Preservation of Mature Vegetation | <input type="checkbox"/> Erosion Control Blanket / Mulching |
| <input type="checkbox"/> Vegetated Buffer Strips | <input type="checkbox"/> Sodding |
| <input type="checkbox"/> Protection of Trees | <input type="checkbox"/> Geotextiles |
| <input type="checkbox"/> Temporary Erosion Control Seeding | <input type="checkbox"/> Other (specify) |
| <input type="checkbox"/> Temporary Turf (Seeding, Class 7) | <input type="checkbox"/> Other (specify) |
| <input type="checkbox"/> Temporary Mulching | <input type="checkbox"/> Other (specify) |
| <input type="checkbox"/> Permanent Seeding | <input type="checkbox"/> Other (specify) |

Describe how the stabilization practices listed above will be utilized during construction:

Describe how the stabilization practices listed above will be utilized after construction activities have been completed:

- C. **Structural Practices:** Provided below is a description of structural practices that will be implemented, to the degree attainable, to divert flows from exposed soils, store flows or otherwise limit runoff and the discharge of pollutants from exposed areas of the site. Such practices may include but are not limited to: perimeter erosion barrier, earth dikes, drainage swales, sediment traps, ditch checks, subsurface drains, pipe slope drains, level spreaders, storm drain inlet protection, rock outlet protection, reinforced soil retaining systems, gabions, and temporary or permanent sediment basins. The installation of these devices may be subject to Section 404 of the Clean Water Act.

The following structural practices will be used for this project:

- | | |
|--|--|
| <input type="checkbox"/> Perimeter Erosion Barrier | <input type="checkbox"/> Rock Outlet Protection |
| <input type="checkbox"/> Temporary Ditch Check | <input type="checkbox"/> Riprap |
| <input type="checkbox"/> Storm Drain Inlet Protection | <input type="checkbox"/> Gabions |
| <input type="checkbox"/> Sediment Trap | <input type="checkbox"/> Slope Mattress |
| <input type="checkbox"/> Temporary Pipe Slope Drain | <input type="checkbox"/> Retaining Walls |
| <input type="checkbox"/> Temporary Sediment Basin | <input type="checkbox"/> Slope Walls |
| <input type="checkbox"/> Temporary Stream Crossing | <input type="checkbox"/> Concrete Revetment Mats |
| <input type="checkbox"/> Stabilized Construction Exits | <input type="checkbox"/> Level Spreaders |
| <input type="checkbox"/> Turf Reinforcement Mats | <input type="checkbox"/> Other (specify) |
| <input type="checkbox"/> Permanent Check Dams | <input type="checkbox"/> Other (specify) |
| <input type="checkbox"/> Permanent Sediment Basin | <input type="checkbox"/> Other (specify) |
| <input type="checkbox"/> Aggregate Ditch | <input type="checkbox"/> Other (specify) |
| <input type="checkbox"/> Paved Ditch | <input type="checkbox"/> Other (specify) |

Describe how the structural practices listed above will be utilized during construction:

Describe how the structural practices listed above will be utilized after construction activities have been completed:

D. **Treatment Chemicals**

Will polymer flocculants or treatment chemicals be utilized on this project: Yes No

If yes above, identify where and how polymer flocculants or treatment chemicals will be utilized on this project.

- E. **Permanent Storm Water Management Controls:** Provided below is a description of measures that will be installed during the construction process to control volume and pollutants in storm water discharges that will occur after construction operations have been completed. The installation of these devices may be subject to Section 404 of the Clean Water Act.

1. Such practices may include but are not limited to: storm water detention structures (including wet ponds), storm water retention structures, flow attenuation by use of open vegetated swales and natural depressions, infiltration of runoff on site, and sequential systems (which combine several practices).

The practices selected for implementation were determined on the basis of the technical guidance in Chapter 41 (Construction Site Storm Water Pollution Control) of the IDOT Bureau of Design and Environment Manual. If practices other than those discussed in Chapter 41 are selected for implementation or if practices are applied to situations different from those covered in Chapter 41, the technical basis for such decisions will be explained below.

2. Velocity dissipation devices will be placed at discharge locations and along the length of any outfall channel as necessary to provide a non-erosive velocity flow from the structure to a water course so that the natural physical and biological characteristics and functions are maintained and protected (e.g. maintenance of hydrologic conditions such as the hydroperiod and hydrodynamics present prior to the initiation of construction activities).

Description of permanent storm water management controls:

- F. **Approved State or Local Laws:** The management practices, controls and provisions contained in this plan will be in accordance with IDOT specifications, which are at least as protective as the requirements contained in the Illinois Environmental Protection Agency's Illinois Urban Manual. Procedures and requirements specified in applicable sediment and erosion site plans or storm water management plans approved by local officials shall be described or incorporated by reference in the space provided below. Requirements specified in sediment and erosion site plans, site permits, storm water management site plans or site permits approved by local officials that are applicable to protecting surface water resources are, upon submittal of an NOI, to be authorized to discharge under the Permit ILR10 incorporated by reference and are enforceable under this permit even if they are not specifically included in the plan.

Description of procedures and requirements specified in applicable sediment and erosion site plans or storm water management plans approved by local officials:

- G. **Contractor Required Submittals:** Prior to conducting any professional services at the site covered by this plan, the Contractor and each subcontractor responsible for compliance with the permit shall submit to the Resident Engineer a Contractor Certification Statement, BDE 2342a.

1. The Contractor shall provide a construction schedule containing an adequate level of detail to show major activities with implementation of pollution prevention BMPs, including the following items:
 - Approximate duration of the project, including each stage of the project
 - Rainy season, dry season, and winter shutdown dates
 - Temporary stabilization measures to be employed by contract phases
 - Mobilization timeframe
 - Mass clearing and grubbing/roadside clearing dates
 - Deployment of Erosion Control Practices
 - Deployment of Sediment Control Practices (including stabilized construction entrances/exits)
 - Deployment of Construction Site Management Practices (including concrete washout facilities, chemical storage, refueling locations, etc.)
 - Paving, saw-cutting, and any other pavement related operations
 - Major planned stockpiling operations
 - Timeframe for other significant long-term operations or activities that may plan non-storm water discharges such as dewatering, grinding, etc.
 - Permanent stabilization activities for each area of the project
2. The Contractor and each subcontractor shall provide, as an attachment to their signed Contractor Certification Statement, a discussion of how they will comply with the requirements of the permit in regard to the following items and provide a graphical representation showing location and type of BMPs to be used when applicable:

- Vehicle Entrances and Exits – Identify type and location of stabilized construction entrances and exits to be used and how they will be maintained.
- Material Delivery, Storage and Use – Discuss where and how materials including chemicals, concrete curing compounds, petroleum products, etc. will be stored for this project.
- Stockpile Management – Identify the location of both on-site and off-site stockpiles. Discuss what BMPs will be used to prevent pollution of storm water from stockpiles.
- Waste Disposal – Discuss methods of waste disposal that will be used for this project.
- Spill Prevention and Control – Discuss steps that will be taken in the event of a material spill (chemicals, concrete curing compounds, petroleum, etc.)
- Concrete Residuals and Washout Wastes – Discuss the location and type of concrete washout facilities to be used on this project and how they will be signed and maintained.
- Litter Management – Discuss how litter will be maintained for this project (education of employees, number of dumpsters, frequency of dumpster pick-up, etc.).
- Vehicle and Equipment Fueling – Identify equipment fueling locations for this project and what BMPs will be used to ensure containment and spill prevention.
- Vehicle and Equipment Cleaning and Maintenance – Identify where equipment cleaning and maintenance locations for this project and what BMPs will be used to ensure containment and spill prevention.
- Dewatering Activities – Identify the controls which will be used during dewatering operations to ensure sediments will not leave the construction site.
- Polymer Flocculants and Treatment Chemicals – Identify the use and dosage of treatment chemicals and provide the Resident Engineer with Material Safety Data Sheets. Describe procedures on how the chemicals will be used and identify who will be responsible for the use and application of these chemicals. The selected individual must be trained on the established procedures.
- Additional measures indicated in the plan.

III. Maintenance:

When requested by the Contractor, the Resident Engineer will provide general maintenance guides to the Contractor for the practices associated with this project. The following additional procedures will be used to maintain, in good and effective operating conditions, the vegetation, erosion and sediment control measures and other protective measures identified in this plan. It will be the Contractor's responsibility to attain maintenance guidelines for any manufactured BMPs which are to be installed and maintained per manufacture's specifications.

IV. Inspections:

Qualified personnel shall inspect disturbed areas of the construction site which have not yet been finally stabilized, structural control measures, and locations where vehicles and equipment enter and exit the site using IDOT Storm Water Pollution Prevention Plan Erosion Control Inspection Report (BC 2259). Such inspections shall be conducted at least once every seven (7) calendar days and within twenty-four (24) hours of the end of a storm or by the end of the following business or work day that is 0.5 inch or greater or equivalent snowfall.

Inspections may be reduced to once per month when construction activities have ceased due to frozen conditions. Weekly inspections will recommence when construction activities are conducted, or if there is 0.5" or greater rain event, or a discharge due to snowmelt occurs.

If any violation of the provisions of this plan is identified during the conduct of the construction work covered by this plan, the Resident Engineer shall notify the appropriate IEPA Field Operations Section office by email at: epa.swnoncomp@illinois.gov, telephone or fax within twenty-four (24) hours of the incident. The Resident Engineer shall then complete and submit an "Incidence of Non-Compliance" (ION) report for the identified violation within five (5) days of the incident. The Resident Engineer shall use forms provided by IEPA and shall include specific information on the cause of noncompliance, actions which were taken to prevent any further causes of noncompliance, and a statement detailing any environmental impact which may have resulted from the noncompliance. All reports of non-compliance shall be signed by a responsible authority in accordance with Part VI. G of the Permit ILR10.

The Incidence of Non-Compliance shall be mailed to the following address:

Illinois Environmental Protection Agency
Division of Water Pollution Control
Attn: Compliance Assurance Section
1021 North Grand East
Post Office Box 19276
Springfield, Illinois 62794-9276

Additional Inspections Required:

V. Failure to Comply:

Failure to comply with any provisions of this Storm Water Pollution Prevention Plan will result in the implementation of a National Pollutant Discharge Elimination System/Erosion and Sediment Control Deficiency Deduction against the Contractor and/or penalties under the Permit ILR10 which could be passed on to the Contractor.

Appendix F
Standard Details

Table of Contents

Stabilized Lot Entrance Standard Detail (SD1).....	F-2
Perimeter Control: Silt Fence Standard Details (SD2).....	F-4
Perimeter Control: Grass Buffer Strip Standard Details (SD3).....	F-6
Perimeter Control: Super Silt Fence Standard Details (SD4).....	F-8
Inlet Protection: Welded Wire Inlet Protection Standard Details (SD5).....	F-10
Inlet Protection: Inlet Filter Protector Standard Details (SD6).....	F-12
Concentrated Flow Control: Rock Check Dam Standard Details (SD7).....	F-15
Concentrated Flow Control: Triangular Silt Dike Standard Details (SD8).....	F-17
Concentrated Flow Control: Diversion Berm Standard Details (SD9).....	F-19
Concentrated Flow Control: Turf Reinforcement Mat Standard Details (SD10).....	F-20
Concentrated Flow Control: Erosion Control Blanket Standard Details (SD11).....	F-23
Concentrated Flow Control: Sodding Standard Details (SD12).....	F-27
Soil Stabilization (non-vegetative): Mulching (SD13).....	F-28
Vegetative Soil Stabilization: Permanent Seeding (SD14).....	F-32
Pump Discharge Filter Bag Standard Details (SD15).....	F-40
Concrete Washout Facilities Standard Details (SD16).....	F-41

(Note: Pamphlet versions of the Storm Water Management and Erosion Control Ordinance may be made available with only Appendix D or Appendix E and therein contain only the relevant details from Appendix F.)

SD1 STABILIZED LOT & CONSTRUCTION ENTRANCE

STABILIZED CONSTRUCTION ENTRANCE DETAIL

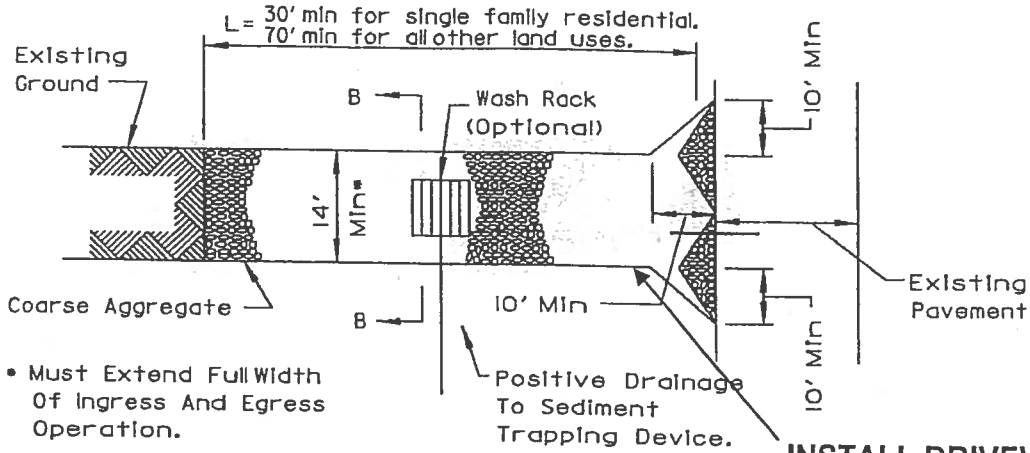

PLAN VIEW

**INSTALL DRIVEWAY
CULVERT IF ROADSIDE
DITCH IS PRESENT**

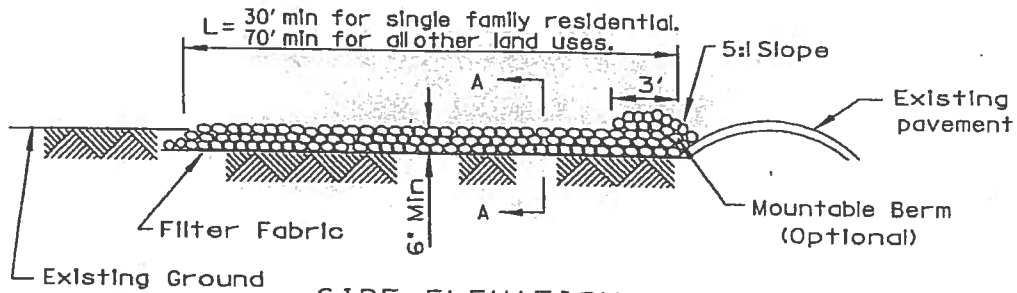

SIDE ELEVATION

NOTES:

1. Filter fabric shall meet the requirements of material specification 592 GEOTEXTILE, Table 1 or 2, Class I, II or IV and shall be placed over the cleared area prior to the placing of rock.
2. Rock or reclaimed concrete shall meet one of the following IDOT coarse aggregate gradation, CA-1, CA-2, CA-3 or CA-4 and be placed according to construction specification 25 ROCKFILL using placement Method I and Class I I compaction.
3. Any drainage facilities required because of washing shall be constructed according to manufacturers specifications.
4. If wash racks are used they shall be installed according to the manufacturer's specifications.

SD1 STABILIZED LOT & CONSTRUCTION ENTRANCE (continued)

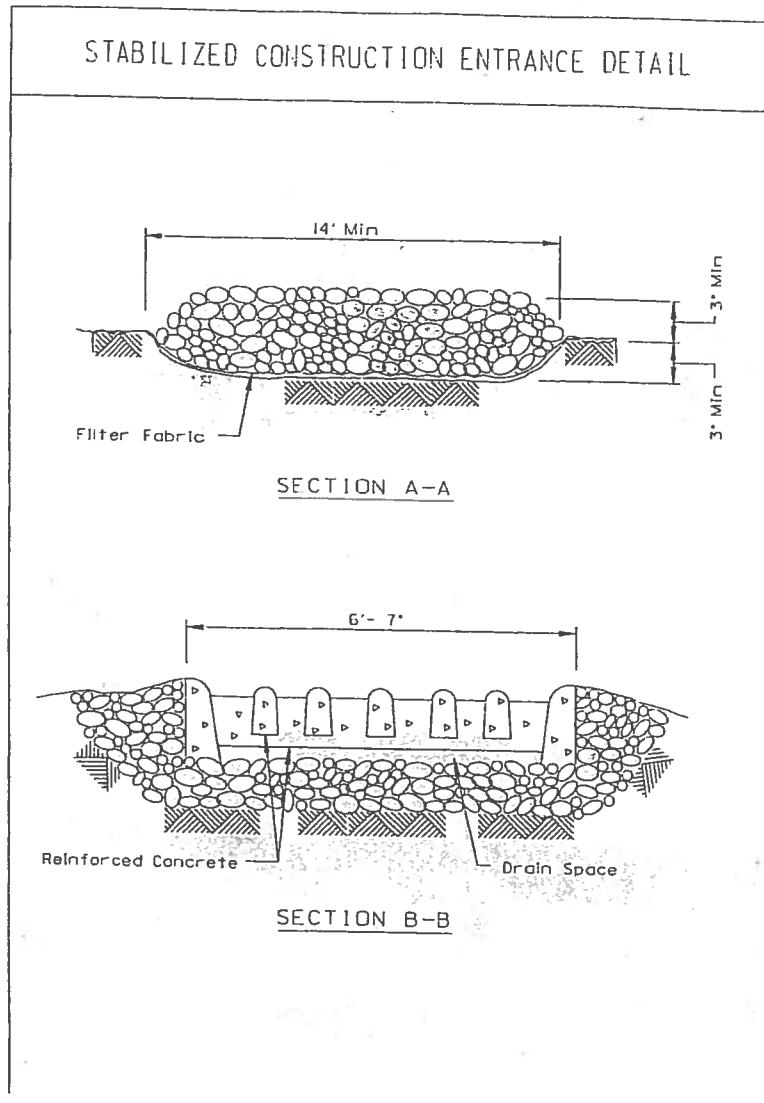

MAINTENANCE:

- 1.) Inspect on a daily basis or as necessary.
- 2.) Immediately remove mud or sediment tracked onto road.
- 3.) Add additional stabilized material as necessary.

SD2 SILT (SEDIMENT) FENCE

PERIMETER BARRIER - SILT FENCE DETAIL

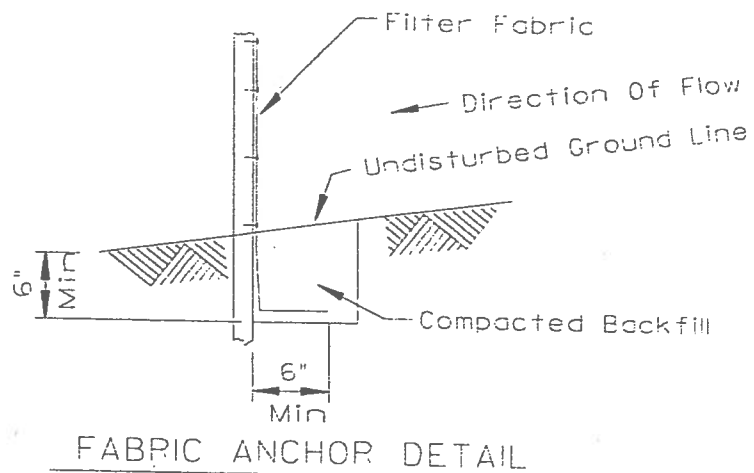
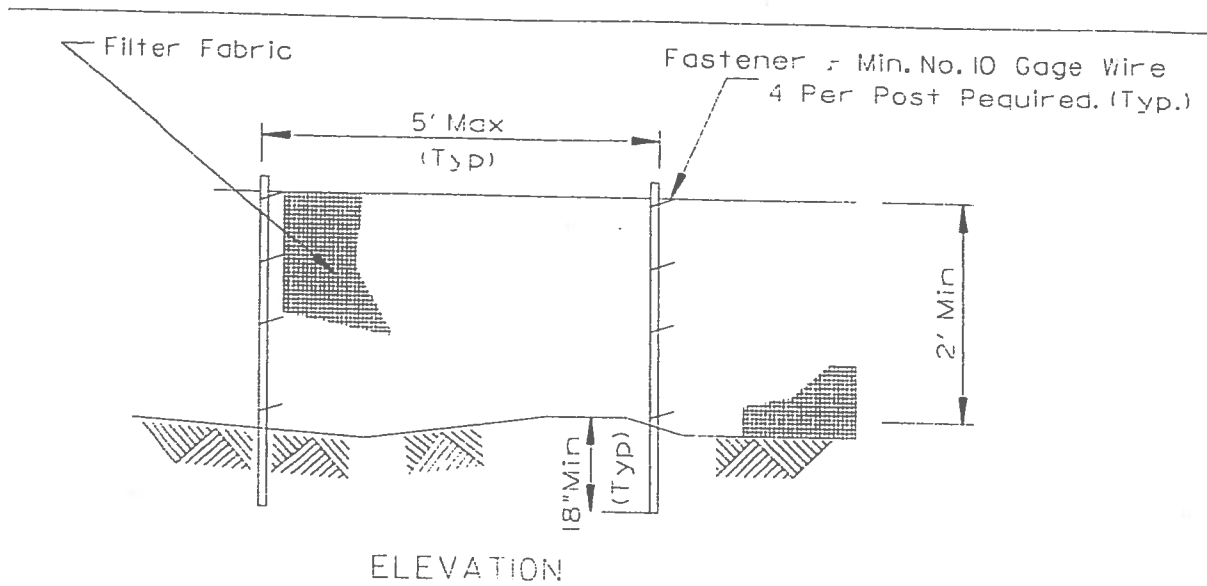

NOTES:

1. Temporary sediment fence shall be installed prior to any grading work in the area to be protected. They shall be maintained throughout the construction period and removed in conjunction with the final grading and site stabilization.
2. Filter fabric shall meet the requirements of material specification 592 Geotextile Table 1 or 2, Class I with equivalent opening size of at least 30 for nonwoven and 50 for woven.
3. Fence posts shall be either standard steel post or wood post with a minimum cross-sectional area of 3.0 sq. in.

SD2 SILT (SEDIMENT) FENCE (continued)

INSTALLATION:

1. Silt fence shall be a minimum of 24 inches above the original ground surface and shall not exceed 36 inches above ground surface.
2. Excavate a trench approximately 6 inches wide and 6 inches deep on the upslope side of the proposed location of the fence. A slicing machine may be used in lieu of trenching.
3. Posts shall be placed a maximum of 5 feet apart. Fabric shall be fastened securely to the upslope side of posts using min. One-inch long, heavy-duty wire staples or tie wires. Eight inches of the fabric shall be extended into the trench. The fabric shall not be stapled to existing trees.
4. The 6 inch by 6 inch trench shall be backfilled and the soil compacted over the textile unless a slicing machine is used.

MAINTENANCE:

1. Inspect on a daily basis or as necessary.
2. Any damage shall be repaired immediately.
3. Sediment must be removed when it reaches 6 inches high on the fence.
4. If geotextile has deteriorated due to ultraviolet breakdown, it shall be replaced.
5. Silt fence shall be removed when it has served its useful purpose, but not before the upslope area has been permanently stabilized.

SD3 GRASS BUFFER STRIP

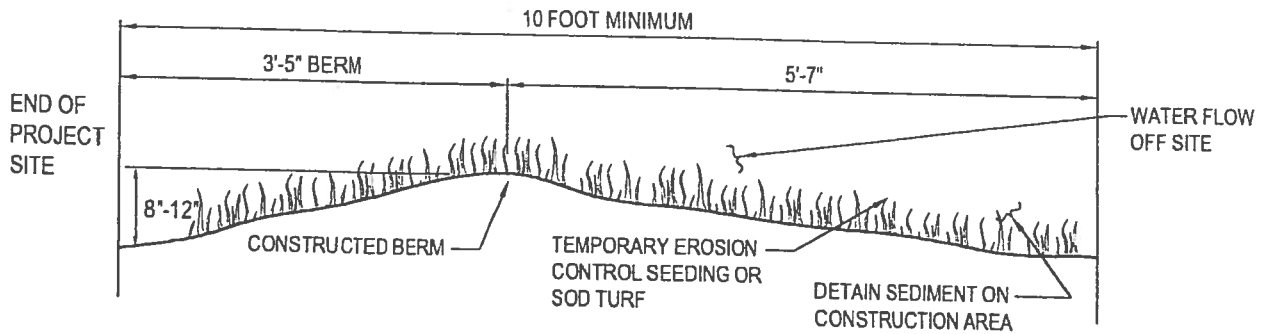
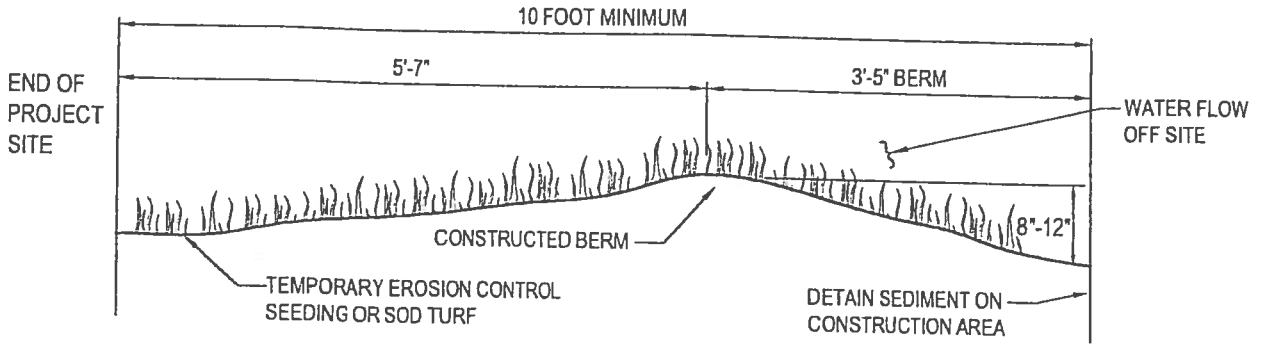

NOTES

SD3 GRASS BUFFER STRIP (continued)**DESCRIPTION:**

These are wide strips of undisturbed vegetation consisting of grass or other erosion resistant plants surrounding the disturbed site. They provide infiltration, intercept sediment and other pollutants, and reduce stormwater flow and velocity. They can also act as a screen for visual pollution and reduce construction noise.

PLANNING CONSIDERATIONS:

Grass strips should be fenced off prior to construction. Avoid storing debris from clearing and grubbing, and other construction waste material in these strips during construction.

DESIGN CRITERIA:

The minimum length of strip must be at least as long as the contributing runoff area. The minimum width should conform to Table below.

MINIMUM WIDTHS OF FILTER STRIPS

SLOPE OF LAND %	WIDTH OF FILTER STRIP FOR GRASSED AREAS (FT)
0	10
2	12
4	14
6	16
8	18
10	20
15	25

INSPECTION AND MAINTENANCE

1. Maintain moist soil conditions immediately after seeding and/or sod installation.
2. Maintain moist soil conditions throughout vegetation establishment period.
3. Sediment deposits should be removed after each storm event.

SD4 SUPER SILT (SEDIMENT) FENCE

PERIMETER BARRIER - SILT FENCE WITH WIRE SUPPORT DETAIL

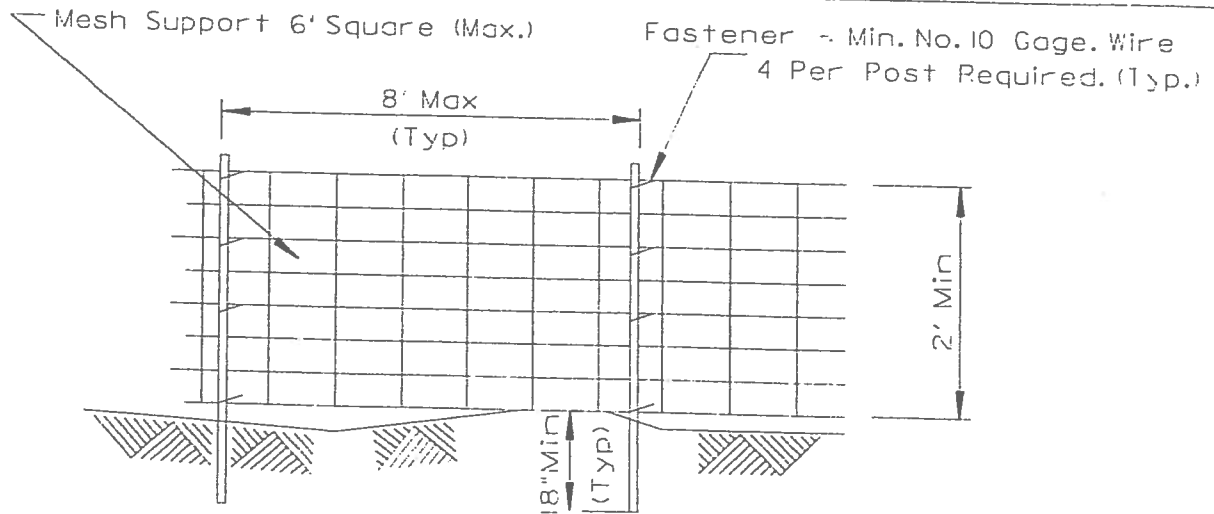

ELEVATION

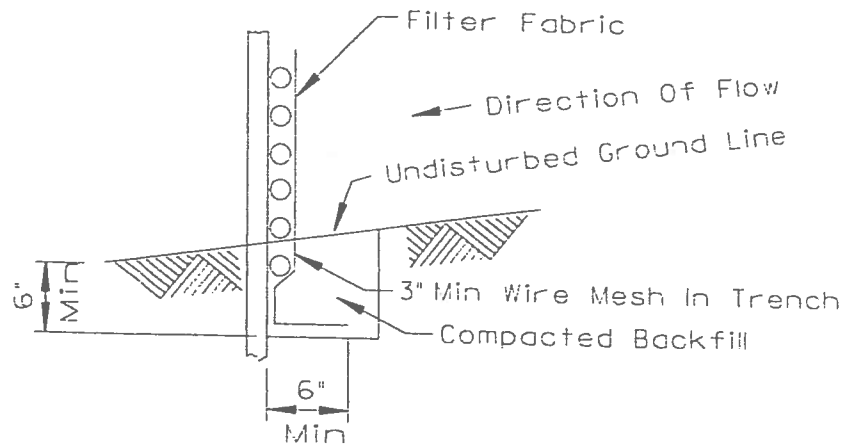

FABRIC ANCHOR DETAIL

NOTES:

1. Wires of mesh support shall be min. gage no. 12.
2. Temporary sediment fence shall be installed prior to any grading work in the area to be protected. They shall be maintained throughout the construction period and removed in conjunction with the final grading and site stabilization.
3. Filter fabric shall meet the requirements of material specification 592 Geotextile Table 1 or 2, Class I with equivalent opening size of at least 30 for nonwoven and 50 for woven.
4. Fence posts shall be either standard steel post or wood post with a minimum cross-sectional area of 3.0 sq. in.

SD4 SUPER SILT (SEDIMENT) FENCE (continued)

INSTALLATION:

1. Silt fence shall be a minimum of 24 inches above the original ground surface and shall not exceed 36 inches above ground surface.
2. Excavate a trench approximately 6 inches wide and 6 inches deep on the upslope side of the proposed location of the fence. A slicing machine may be used in lieu of trenching.
3. Posts shall be placed a maximum of 5 feet apart. Fabric shall be fastened securely to the upslope side of posts using min. One-inch long, heavy-duty wire staples or tie wires. Eight inches of the fabric shall be extended into the trench. The fabric shall not be stapled to existing trees.
4. The 6 inch by 6 inch trench shall be backfilled and the soil compacted over the textile unless a slicing machine is used.

MAINTENANCE:

1. Inspect on a daily basis or as necessary.
2. Any damage shall be repaired immediately.
3. Sediment must be removed when it reaches 6 inches high on the fence.
4. If geotextile has deteriorated due to ultraviolet breakdown, it shall be replaced.
5. Silt fence shall be removed when it has served its useful purpose, but not before the upslope area has been permanently stabilized.

SD5 WELDED WIRE INLET PROTECTOR

WELDED WIRE / MONOFILAMENT INLET PROTECTORS

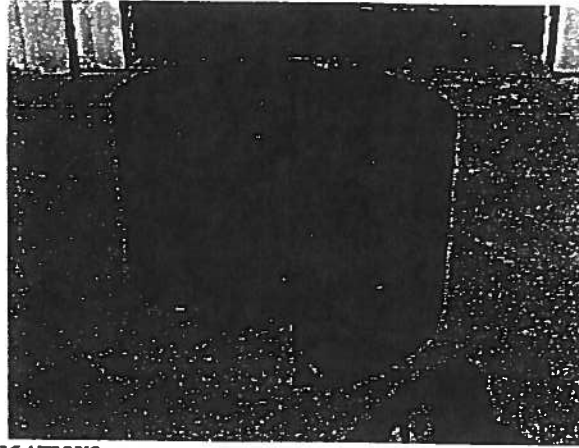

SPECIFICATIONS

Description: Inlet protector shall consist of three (3) parts:

1. 35' wide geotextile fabric shall be Mirafl® FF101. Mirafl® FF101 is composed of high-tenacity monofilament polypropylene yarns, which are woven into a stable network such that the yarns remain their relative position. FF101 is inert to biological degradation and resistant to naturally encountered chemicals, alkalis, and acids.
2. 6' x 6" welded wire mesh geotextile composite, shall be 30" tall, formed and secured into a 42" minimum diameter circle.
3. Fastening rings shall be constructed of wire conforming to ASTM A-641, A-309, A-370, and A-938.

Assembly

Geotextile shall be wrapped three inches over the top member of the 6" x 6" welded wire mesh and secured with fastening rings at six inches on center. Geotextile shall be secured to the sides of the welded wire mesh with fastening rings at a spacing of one per square foot. The fastening rings shall penetrate both layers of geotextile and securely close around a steel member.

Geotextile

<u>Mechanical/Physical Properties</u>	<u>Description/Minimum Average Roll Values</u>	<u>Test Method</u>
Structure	Woven Monofilament	
Polymer	Polypropylene	
U.V. Resistance (at 500hrs)	80% Strength Retained	ASTM D4355
Permeability	2.9 Sec-1	ASTM D4491
Flow Rate	100 gpm ft ²	ASTM D4491
Grab Tensile Strength (min)	130 lbs	ASTM D4632
AOS (U.S. Sieve)	30	ASTM D4751
Mullen Burst Strength	175 psi	ASTM D3786
Color	Orange or Black	

Welded Wire Mesh

6" x 6" welded wire mesh shall be formed of 10 gauge steel conforming to ASTM A-165.

SILT FENCE FABRICATORS, LLC
PHONE: (317) 338-0599

P.O. BOX 36

GREENWOOD, IN 46142
Rev. 2/12/05

SD5 WELDED WIRE INLET PROTECTOR (continued)

MAINTENANCE:

1. Excavate a trench approximately 6 inches wide and 6 inches deep the proposed location of the inlet protector.
2. The 6 inch by 6 inch trench shall be backfilled and the soil compacted over the textile

MAINTENANCE:

1. Inspect on a daily basis or as necessary.
2. Any damage shall be repaired immediately.
3. Sediment must be removed when it reaches 6 inches high on the basket.
4. If geotextile has deteriorated due to ultraviolet breakdown, it shall be replaced.
5. Inlet protector shall be removed when it has served its useful purpose, but not before the upslope area has been permanently stabilized.

SD6 INLET FILTER PROTECTOR

IPP INLET FILTERS

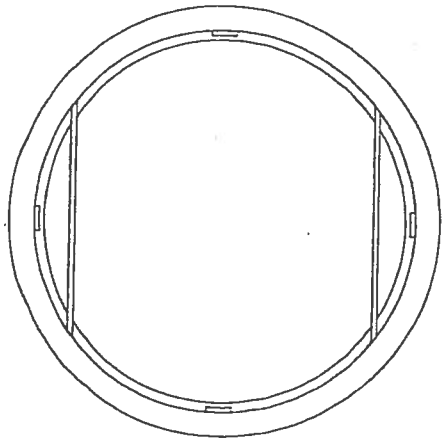

IDOT Type 1 Round Inlet Filter Depicted
NOTE: Round and Square/Rectangular Inlet Filters Available for most Neeneh and East Jordan Beehive, Roll Curb and Curb Box Frame Types

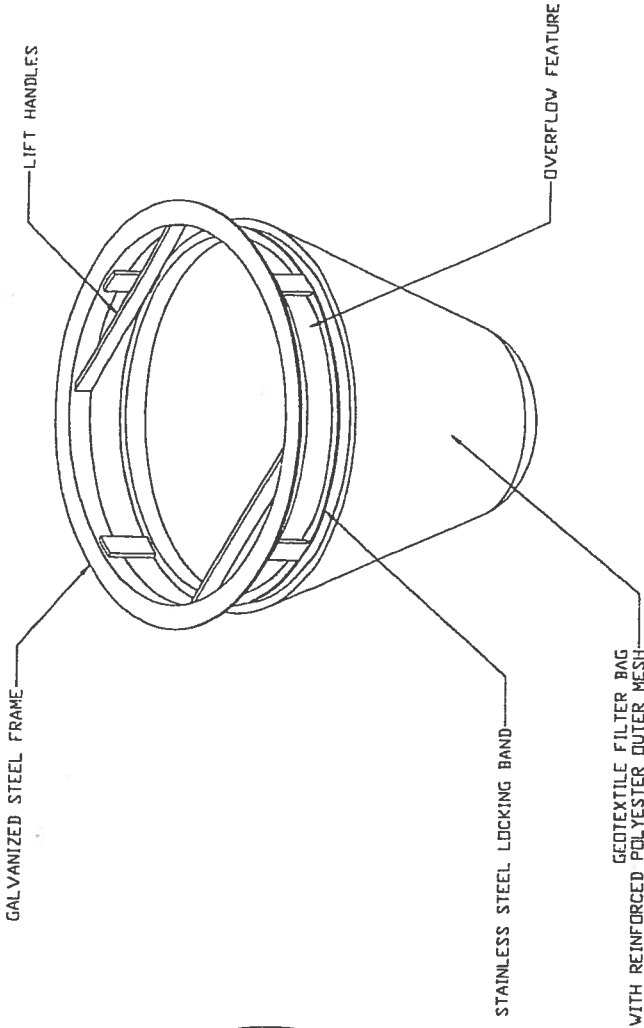

INLET FILTER SPECIFICATION

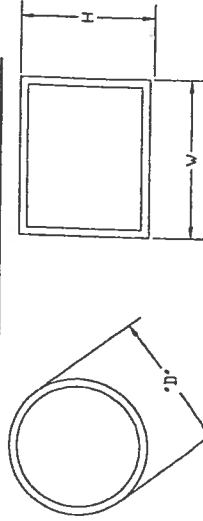

Note: Inlet Filters are slightly smaller than the inlet grate sizes. When identifying or specifying filters/castings please refer to the diameter "D" or width "W" and height "H" of filter frames or casting grates. You may also refer to our standards. You may also refer to our casting cross reference guide for IDOT standards.

All Products Manufactured by Inlet & Pipe Protection, Inc
www.inletfilters.com
 (847) 722-0690 ph
 (847) 364-5262 fx
sales@inletfilters.com

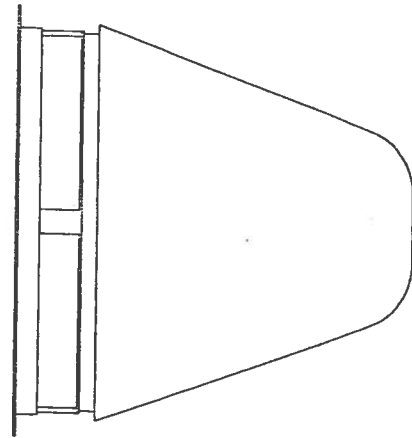

***** Certification: All IPP Inlet Filters conform to IDOT Specifications as outlined in Article 1081.15 of IDOT's Standard Specifications Guide**

SD6 INLET FILTER PROTECTOR (continued)

THE FOLLOWING PRODUCTS ARE
APPROVED FOR INLET PROTECTION

IPP INLET FILTERS

3535 Stackinghay
Naperville, IL 60564
847-722-0690 Telephone
847-364-5262 Fax

www.inletfilters.com

CATCH-ALL INLET PROTECTOR
MARATHON MATERIALS, INC.

25523 WEST SCHULTZ STREET
PLAINFIELD, ILLINOIS 60544
(630) 983-9494 Tel
(800) 983-9493 Toll Free
(630) 983-9580 Fax

www.marathonmaterials.com

OTHER PRODUCTS CAN BE SUBMITTED
FOR REVIEW AND APPROVAL

SD6 INLET FILTER PROTECTOR (continued)

INSTALLATION:

All inlet filter protectors shall be installed in accordance with manufacturer's instructions.

MAINTENANCE

1. Inspect on a daily basis or as necessary.
2. Any damage to products shall be repaired immediately.
3. Sediment must be removed when it reaches 1/3 the height of the product.
4. Inlet protection shall be removed when it has served its useful purpose, but not before upslope area has been permanently stabilized.

SD7 ROCK CHECK DAM

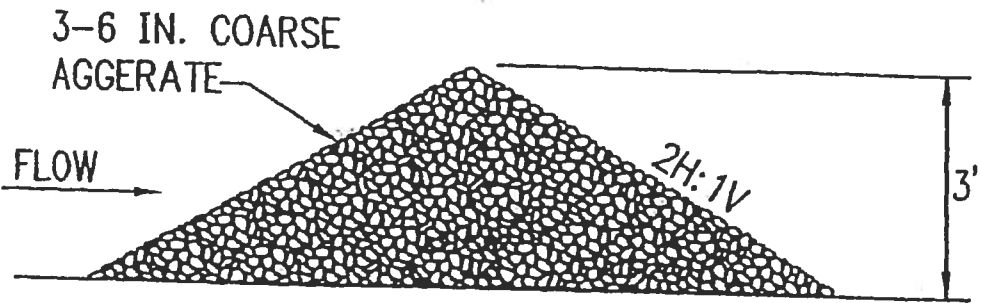
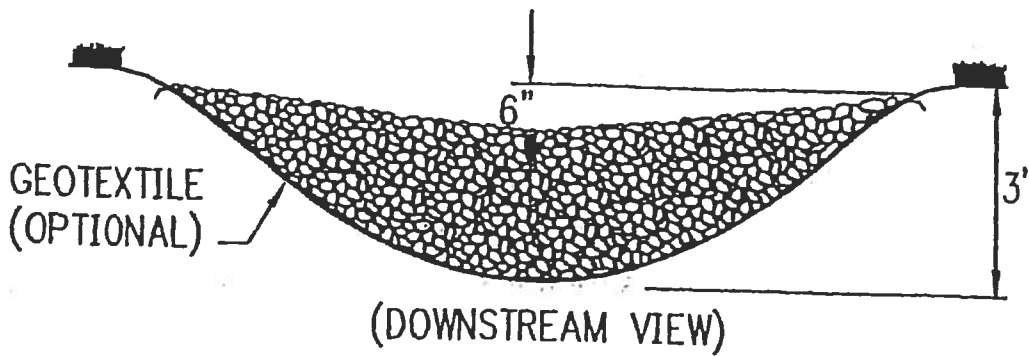

SPACING BETWEEN CHECK DAMS:

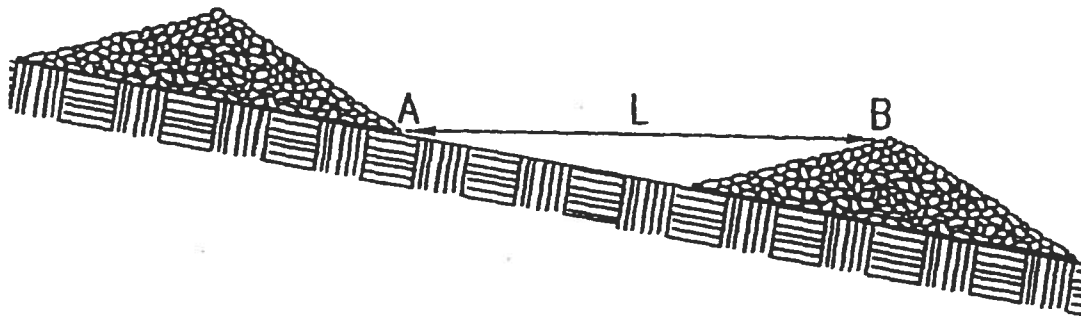

L = DISTANCE SUCH THAT POINTS
A AND B ARE OF EQUAL ELEVATION.

SD7 ROCK CHECK DAM (continued)

NOTES:

1. The maximum height of the dam shall be 3.0 feet.
2. The center of the check dam must be at least 6 inches lower than the outer edges.
3. For added stability, the base of the check dam can be keyed into the soil approximately 6 inches.
4. The dams should be spaced so the toe of the upstream dam is at the same elevation as the top of the downstream dam.
5. Stone should be placed according to the detail. Hand or Mechanical placement will be necessary to achieve complete coverage of the ditch or swale and to ensure that the center of the dam is lower than the edges.
6. Geotextile may be used under the stone to provide a stable foundation and to facilitate removal of the stone.
7. Check dams should be inspected for sediment accumulation after each runoff producing storm event. Sediment should be removed when it reaches half of the original height of the measure.
8. Regular inspection should be made to ensure that the center of the dam is lower than the edges. Erosion caused by high flows around the edges of the dam should be corrected immediately.

SD8 TRIANGULAR SILT DIKE

TRIANGULAR SILT DIKE INSTALLATION FOR ROADWAY DITCH OF DRAINAGE DITCH

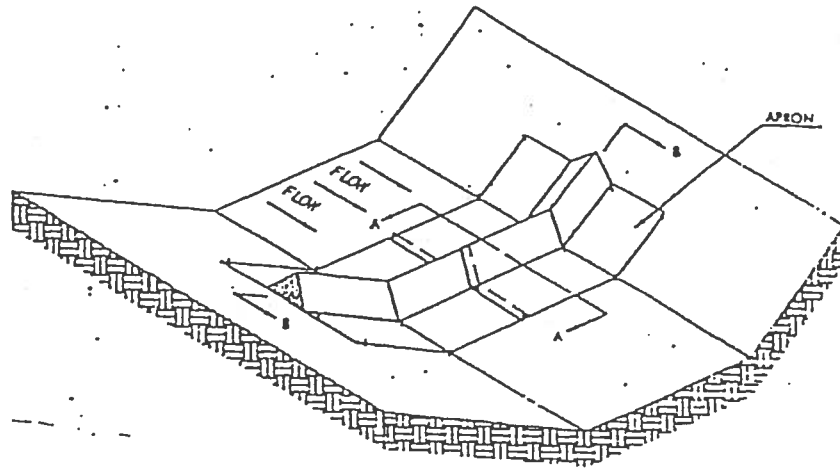

SILT DIKE UNIT
CUT SECTION

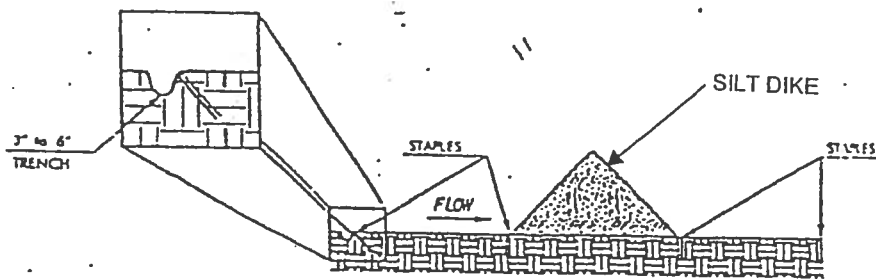

DETAIL A-A

● STAPLES SHALL BE PLACED WHERE THE UNITS OVERLAP AND IN THE CENTER OF THE 7" UNIT AS SHOWN ON THE DIAGRAM.

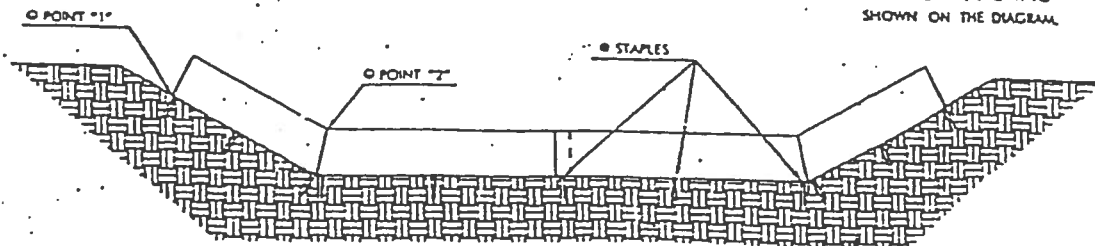

DIKE SECTION
DETAIL B-B

POINT "1" MUST BE HIGHER THAN POINT "2" TO ENSURE THAT WATER FLOWS OVER THE DIKE AND NOT AROUND THE ENDS.

SD8 TRIANGULAR SILT DIKE (continued)

INSTALLATION:

1. Excavate a trench approximately 3-6 inches wide and 3-6 inches deep on the upslope side of the proposed location of the dike.
2. The 3-6 inch by 3-6 inch trench shall be backfilled and the soil compacted over the textile .

MAINTENANCE:

1. Inspect on a daily basis or as necessary.
2. Any damage shall be repaired immediately.
3. Sediment must be removed when it reaches 6 inches high on the dike.
4. If geotextile has deteriorated due to ultraviolet breakdown, it shall be replaced.
5. Dike shall be removed when it has served its useful purpose, but not before the upslope area has been permanently stabilized.

SD9 DIVERSION BERM

TEMPORARY FILL DIVERSION NOTES:

1. THE DIVERSION SHALL BE CONSTRUCTED AT THE TOP OF THE FILL AT THE END OF EACH WORK DAY AS NEEDED.
2. THE DIVERSION SHALL BE LOCATED AT LEAST 2 FEET INSIDE THE TOP EDGE OF THE FILL.
3. THE SUPPORTING RIDGE SHALL BE CONSTRUCTED WITH A UNIFORM HEIGHT ALONG ITS ENTIRE LENGTH, WITHOUT UNIFORM HEIGHT; THE FILL DIVERSION MAY BE SUSCEPTIBLE TO BREACHING.

RIGHT-OF-WAY DIVERSION DETAIL NOTES:

1. THE DIVERSION SHALL BE INSTALLED AS SOON AS THE RIGHT-OF-WAY HAS BEEN CLEARED AND/OR GRADED.
2. ALL EARTHEN DIVERSIONS SHALL BE MACHINE- OR HAND-COMPACTED IN 8-INCH LIFTS.
3. THE OUTLET OF THE DIVERSION SHALL BE LOCATED ON AN UNDISTURBED AND STABILIZED AREA WHEN AT ALL POSSIBLE. THE FIELD LOCATION SHOULD BE ADJUSTED AS NEEDED TO UTILIZE A STABILIZED OUTLET.
4. EARTHEN DIVERSIONS WHICH WILL NOT BE SUBJECT TO CONSTRUCTION TRAFFIC SHOULD BE STABILIZED IN ACCORDANCE WITH TEMPORARY SEEDING.

DIVERSION DETAIL NOTES:

1. ALL TREES, BRUSH, STUMPS, OBSTRUCTIONS, AND OTHER OBJECTIONABLE MATERIAL SHALL BE REMOVED AND DISPOSED OF SO AS NOT TO INTERFERE WITH THE PROPER FUNCTIONING OF THE DIVERSION.
2. THE DIVERSION SHALL BE EXCAVATED OR SHAPED TO LINE, GRADE, AND CROSS-SECTION AS REQUIRED TO MEET THE CRITERIA SPECIFIED HEREIN, FREE OF IRREGULARITIES WHICH WILL IMPEDE FLOW.
3. FILLS SHALL BE COMPACTED AS NEEDED TO PREVENT UNEQUAL SETTLEMENT THAT WOULD CAUSE DAMAGE IN THE COMPLETED DIVERSION. FILL SHALL BE COMPOSED OF SOIL WHICH IS FREE FROM EXCESSIVE ORGANIC DEBRIS, ROCKS OR OTHER OBJECTIONABLE MATERIALS.
4. ALL EARTH REMOVED AND NOT NEEDED IN CONSTRUCTION SHALL BE SPREAD OR DISPOSED OF SO THAT IT WILL NOT INTERFERE WITH THE FUNCTIONING OF THE DIVERSION.
5. PERMANENT STABILIZATION OF DISTURBED AREAS SHALL BE DONE IN ACCORDANCE WITH SECTION 2151.

TEMPORARY RIGHT-OF-WAY DIVERSIONS

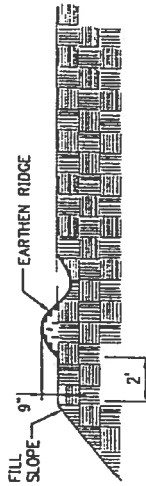

TEMPORARY FILL DIVERSION

NOT TO SCALE

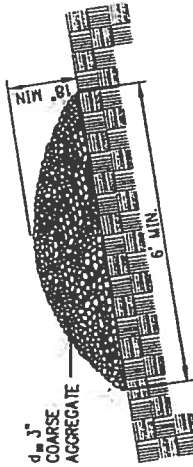

TYPICAL GRAVEL STRUCTURE

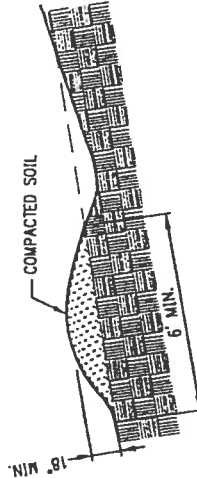

TYPICAL EARTHEN STRUCTURE

TEMPORARY DIVERSION DIKE NOTES:

1. TEMPORARY DIVERSION DIKES MUST BE INSTALLED AS A FIRST STEP IN THE LAND-DISTURBING ACTIVITY AND MUST BE FUNCTIONAL PRIOR TO UPSLOPE LAND DISTURBANCE.
2. THE DIKE SHOULD BE ADEQUATELY COMPACTED TO PREVENT FAILURE.
3. TEMPORARY OR PERMANENT SEEDING AND MULCH SHALL BE APPLIED TO THE DIKE IMMEDIATELY FOLLOWING ITS CONSTRUCTION.
4. THE DIKE SHOULD BE LOCATED TO MINIMIZE DAMAGES BY CONSTRUCTION OPERATIONS.

DIVERSIONS

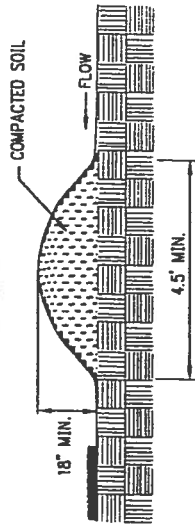

TEMPORARY DIVERSION DIKE

NOT TO SCALE

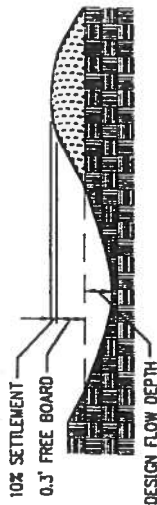

TYPICAL PARABOLIC DIVERSION

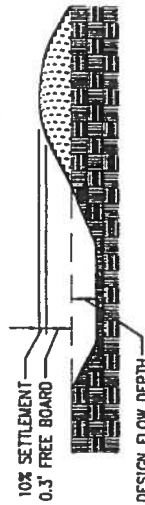

TYPICAL TRAPEZOIDAL DIVERSION

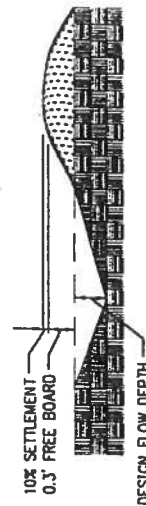

TYPICAL VEE-SHAPED DIVERSION

SD10 TURF REINFORCEMENT MAT

TURF REINFORCEMENT MAT SLOPE INSTALLATION NOTES:

A) TURF REINFORCEMENT MAT:

1. THE MAJORITY OF THESE PRODUCTS PROVIDE A THREE DIMENSIONAL GEOMATRIX OF NYLON, POLYETHYLENE, OR RANDOMLY ORIENTED MONOPLAMENTS, FORMING A MAT. THESE PRODUCTS CONTAIN ULTRA VIOLET (UV) INHIBITING STABILIZERS, ADDED TO THE COMPOUNDS TO ENSURE ENDURANCE AND PROVIDE "PERMANENT ROOT REINFORCEMENT." THE THREE DIMENSIONAL FEATURE CREATES AN OPEN SPACE WHICH IS ALLOWED TO FILL WITH SOIL. THE ROOTS OF THE GRASS PLANT BECOME ESTABLISHED WITHIN THE MAT ITSELF, FORMING A SYNERGISTIC ROOT AND MAT SYSTEM. AS THE GRASS BECOMES ESTABLISHED, THE TWO ACTUALLY "REINFORCE" EACH OTHER, PREVENTING MOVEMENT OR DAMAGE TO THE SOIL. ALLOWABLE VELOCITIES ARE INCREASED CONSIDERABLY OVER NATURAL TURF STANDS. SELECTION OF THE APPROPRIATE MATTING MATERIALS ALONG WITH PROPER INSTALLATION BECOME CRITICAL FACTORS IN THE SUCCESS OF THIS PRACTICE. CONSULTATION WITH THE SUPPLIER OR THE MANUFACTURER AND THOROUGH EVALUATION OF PERFORMANCE DATA TO ENSURE PROPER SELECTION OF A SOIL STABILIZATION MATTING ARE ALSO ESSENTIAL. ALTHOUGH MANY MANUFACTURERS CLAIM THEIR PRODUCTS MAY INHIBIT EROSION ASSOCIATED WITH CHANNEL VELOCITIES OF UP TO 20 FT./SEC., IT IS RECOMMENDED THAT ANY VELOCITIES THAT EXCEED 10 FT./SEC. BE PROPERLY PREVENTED WITH SOME FORM OF STRUCTURAL LINING.

B) INSTALLATION REQUIREMENTS:

- SITE PREPARATION:**
AFTER SITE HAS BEEN SHAPED AND GRADED TO APPROVED DESIGN, PREPARE A FRILABLE SEEDBED RELATIVELY FREE FROM CLODS AND ROCKS MORE THAN 1-INCH IN DIAMETER, AND ANY FOREIGN MATERIAL THAT WILL PREVENT CONTACT OF THE SOIL STABILIZATION MAT WITH THE SOIL SURFACE. IF NECESSARY, REDIRECT ANY RUNOFF AWAY FROM THE DITCH OR SLOPE DURING INSTALLATION.
- PLANTING:**
LIME, FERTILIZE AND SEED IN ACCORDANCE WITH THE APPROVED PLAN, PAYING SPECIAL ATTENTION TO THE PLANT SELECTION THAT MAY HAVE BEEN CHOSEN FOR THE WAITED AREA. IF THE AREA HAS BEEN SEEDDED PRIOR TO INSTALLING THE MAT, MAKE SURE AND RESEED ALL AREAS DISTURBED DURING INSTALLATION.
- LAYING AND SECURING:**
SIMILAR TO INSTALLING OTHER EROSION CONTROL BLANKETS, BUT PLAN APPROVING AUTHORITY'S REQUIREMENTS OR MANUFACTURER'S RECOMMENDATIONS MUST BE FOLLOWED AS DETAILED. THE KEY TO ACHIEVING DESIRED PERFORMANCE IS DEPENDENT UPON PROPER INSTALLATION.
- CHECK SLOTS:**
BLANKET MANUFACTURERS VARY SIGNIFICANTLY IN THEIR CHECK SLOT REQUIREMENTS. SIMILAR TO THE INSTALLATION OF OTHER BLANKETS, A CHECK SLOT MAY BE REQUIRED WHEN LAYING TURF REINFORCEMENT MAT TO "CORRECT" THE FLOW OF WATER IF IT HAS THE POTENTIAL TO UNDERMINE THE BLANKET. MOST AUTHORITIES REQUIRE THAT THE SIDES OF THE BLANKET ALSO BE ENTRENCHED, CREATING A SLOPE SHELF FOR THE MATERIAL TO REST ON, PREVENTING WATER FROM ENTERING UNDER THE BLANKET ON THE SIDES.
- SECURING THE MATERIAL AND JOINING BLANKETS:**
AGAIN, PRODUCT SPECIFICATIONS VARY - UPSTREAM AND DOWNSTREAM TERMINAL SLOTS, NEW ROLL OVERLAPS AND MULTIPLE WIDTH INSTALLATIONS DIFFER BY VARIOUS PRODUCTS AND MANUFACTURERS.
- FINAL CHECKS:**
THESE INSTALLATION TECHNIQUES MUST BE ADHERED TO:
 - SOIL STABILIZATION BLANKET IS IN UNIFORM CONTACT WITH THE SOIL
 - ALL REQUIRED SLOTS AND LAPPED JOINTS ARE IN PLACE.
 - THE MATERIAL IS PROPERLY ANCHORED.
 - ALL DISTURBED AREAS ARE SEEDDED.

TURF REINFORCEMENT MAT INSTALLATION ON A SLOPE

- NOTES:**
- SOIL STABILIZATION SHOULD BE INSTALLED VERTICALLY DOWNSLOPE FOR BEST RESULTS.
 - SLOPE SURFACE SHALL BE SMOOTH AND FREE OF ROCKS, LUMPS OF DIRT, GRASS AND STICKS, MAT SHALL BE PLACED FLAT ON SURFACE FOR PROPER SOIL CONTACT.

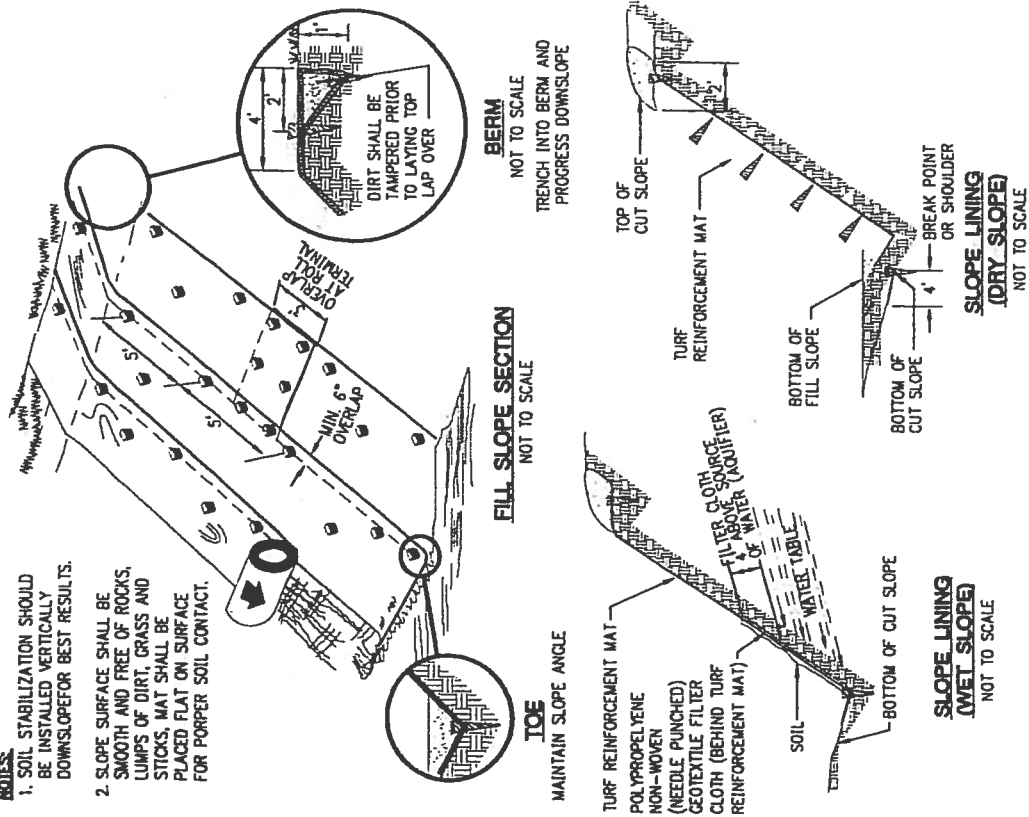

SD10 TURF REINFORCEMENT MAT (continued)

TURF REINFORCEMENT MAT CHANNEL INSTALLATION NOTES:
A) TURF REINFORCEMENT MAT:

1. THE MAJORITY OF THESE PRODUCTS PROVIDE A THREE DIMENSIONAL GEOMATRIX OF NYLON, POLYETHYLENE, OR RANDOMLY ORIENTED MONOFILAMENTS, FORMING A MAT. THESE PRODUCTS CONTAIN ULTRA VIOLET (UV) INHIBITING STABILIZERS, ADDED TO THE COMPOUNDS TO ENSURE ENDURANCE AND PROVIDE "PERMANENT ROOT REINFORCEMENT." THE THREE DIMENSIONAL FEATURE CREATES AN OPEN SPACE WHICH IS ALLOWED TO FILL WITH SOIL. THE ROOTS OF THE GRASS PLANT BECOME ESTABLISHED WITHIN THE MAT ITSELF, FORMING A SYNERGISTIC ROOT AND MAT SYSTEM. AS THE GRASS BECOMES ESTABLISHED, THE TWO ACTUALLY "REINFORCE" EACH OTHER, PREVENTING MOVEMENT OR DAMAGE TO THE SOIL. ALLOWABLE VELOCITIES ARE INCREASED CONSIDERABLY OVER NATURAL TURF STANDS. SELECTION OF THE APPROPRIATE MATTING MATERIALS ALONG WITH PROPER INSTALLATION BECOME CRITICAL FACTORS IN THE SUCCESS OF THIS PRACTICE. CONSULTATION WITH THE SUPPLIER OR THE MANUFACTURER AND THOROUGH EVALUATION OF PERFORMANCE DATA TO ENSURE PROPER SELECTION OF A SOIL STABILIZATION MATTING ARE ALSO ESSENTIAL. ALTHOUGH MANY MANUFACTURERS CLAIM THEIR PRODUCTS MAY INHIBIT EROSION ASSOCIATED WITH CHANNEL VELOCITIES OF UP TO 20 FT./SEC. FOR SHORT PERIODS OF TIME, IT IS RECOMMENDED THAT ANY VELOCITIES THAT EXCEED 10 FT./SEC. BE PROPERLY ARMORED WITH SOME FORM OF STRUCTURAL LINING.

B) INSTALLATION REQUIREMENTS:

1. **SITE PREPARATION:**
 AFTER SITE HAS BEEN SHAPED AND GRADED TO APPROVED DESIGN, PREPARE A FRIABLE SEEDBED RELATIVELY FREE FROM CLODS AND ROCKS MORE THAN 1-INCH IN DIAMETER, AND ANY FOREIGN MATERIAL THAT WILL PREVENT CONTACT OF THE SOIL STABILIZATION MAT WITH THE SOIL SURFACE. IF NECESSARY, REDIRECT ANY RUNOFF AWAY FROM THE DITCH OR SLOPE DURING INSTALLATION.
2. **PLANTING:**
 LIME, FERTILIZE AND SEED IN ACCORDANCE WITH THE APPROVED PLAN, PAYING SPECIAL ATTENTION TO THE PLANT SELECTION THAT MAY HAVE BEEN CHOSEN FOR THE MATTED AREA. IF THE AREA HAS BEEN SEEDED PRIOR TO INSTALLING THE MAT, MAKE SURE AND RESEED ALL AREAS DISTURBED DURING INSTALLATION.
3. **LAYING AND SECURING:**
 SIMILAR TO INSTALLING OTHER EROSION CONTROL BLANKETS, BUT PLAN APPROVING AUTHORITY'S REQUIREMENTS OR MANUFACTURER'S RECOMMENDATIONS MUST BE FOLLOWED AS DETAILED. THE KEY TO ACHIEVING DESIRED PERFORMANCE IS DEPENDENT UPON PROPER INSTALLATION.
4. **CHECK SLOTS:**
 BLANKET MANUFACTURERS VARY SIGNIFICANTLY IN THEIR CHECK SLOT REQUIREMENTS. SIMILAR TO THE INSTALLATION OF OTHER BLANKETS, A CHECK SLOT MAY BE REQUIRED WHEN LAYING TURF REINFORCEMENT MAT TO "CORRECT" THE FLOW OF WATER IF IT HAS THE POTENTIAL TO UNDERMINE THE BLANKET. MOST AUTHORITIES REQUIRE THAT THE SIDES OF THE BLANKET ALSO BE ENTRENCHED, CREATING A SLOPE SHELF FOR THE MATERIAL TO REST ON, PREVENTING WATER FROM ENTERING UNDER THE BLANKET ON THE SIDES.
5. **SECURING THE MATERIAL AND JOINING BLANKETS:**
 AGAIN, PRODUCT SPECIFICATIONS VARY - UPSTREAM AND DOWNSTREAM TERMINAL SLOTS, NEW ROLL OVERLAPS AND MULTIPLE WIDTH INSTALLATIONS DIFFER BY VARIOUS PRODUCTS AND MANUFACTURERS.

6. **FINAL CHECK:**

- THESE INSTALLATION TECHNIQUES MUST BE ADHERED TO:
- a. SOIL STABILIZATION BLANKET IS IN UNIFORM CONTACT WITH THE SOIL
 - b. ALL REQUIRED SLOTS AND LAPPED JOINTS ARE IN PLACE.
 - c. THE MATERIAL IS PROPERLY ANCHORED.
 - d. ALL DISTURBED AREAS ARE SEEDD

TURF REINFORCEMENT MAT INSTALLATION IN A CHANNEL

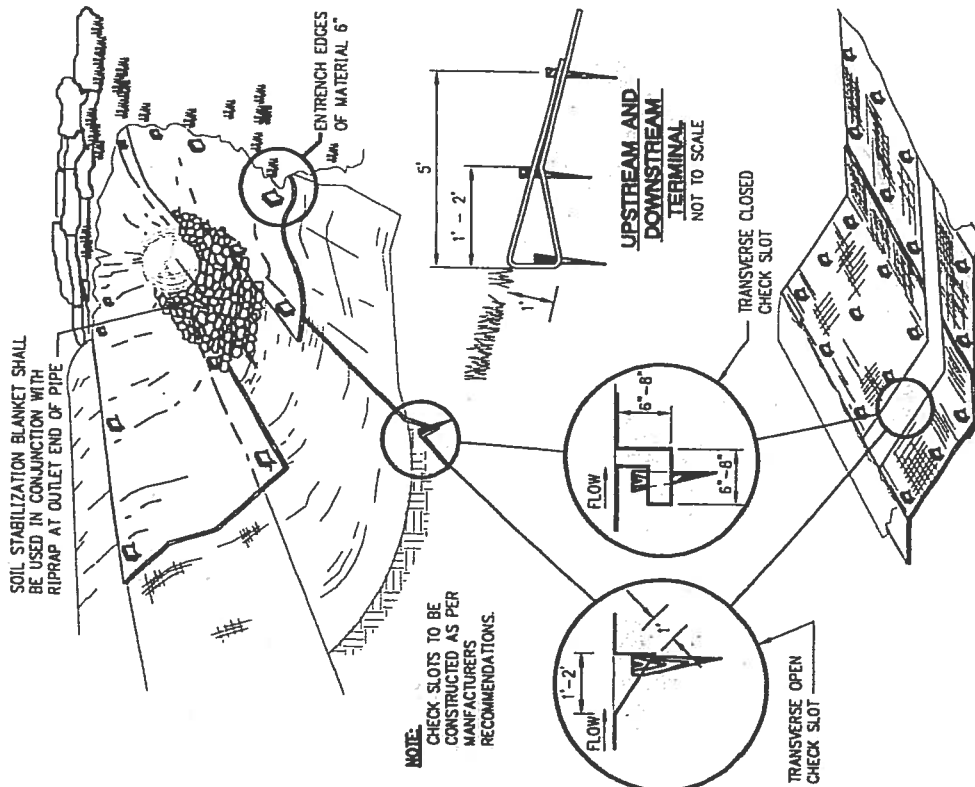

SD10 TURF REINFORCEMENT MAT (continued)

STAKES, STAPLES, AND PINS NOTES:
A) GENERAL NOTES:

1. 1x4 TRIANGULAR SURVEY STAKE - MINIMUM 10" IN LENGTH. PLACEMENT OF THE STAKE ACROSS THE FLOW OF THE WATER IS THOUGHT TO PROVIDE A "PINBALL EFFECT" TO HELP SLOW THE VELOCITY.
2. 11 GAUGE STEEL - MINIMUM 1" WIDE BY 6" IN LENGTH STEEL STAPLE - 2"x8" STAPLE MAY BE REQUIRED IN CERTAIN SOIL CONDITIONS.
3. STEEL PINS - 3/16" DIA. STEEL PIN BY 18" IN LENGTH WITH A 2" DIA. WASHER ON TOP. (SEE ILLUSTRATION)
4. STAPLES OR ANCHORING METHODS AND RECOMMENDATIONS VARY BY MANUFACTURERS. THE EXPECTATIONS OF HIGH VELOCITIES SHOULD DICTATE THE USE OF MORE SUBSTANTIAL ANCHORING.

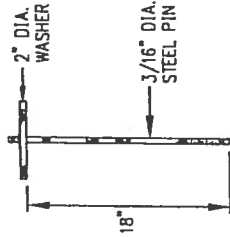

3. PIN
SEE NOTE 3

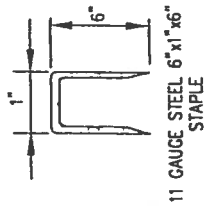

11 GAUGE STEEL 6"x1"x6" STAPLE

2. STAPLE
SEE NOTE 2

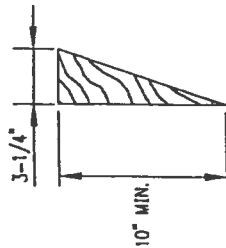

1. STAKE
SEE NOTE 1

**STAKES, STAPLES, AND PINS
 FOR INSTALLATION OF
 ROLLED EROSION CONTROL PRODUCTS**
 NOT TO SCALE

SD11 EROSION CONTROL BLANKET

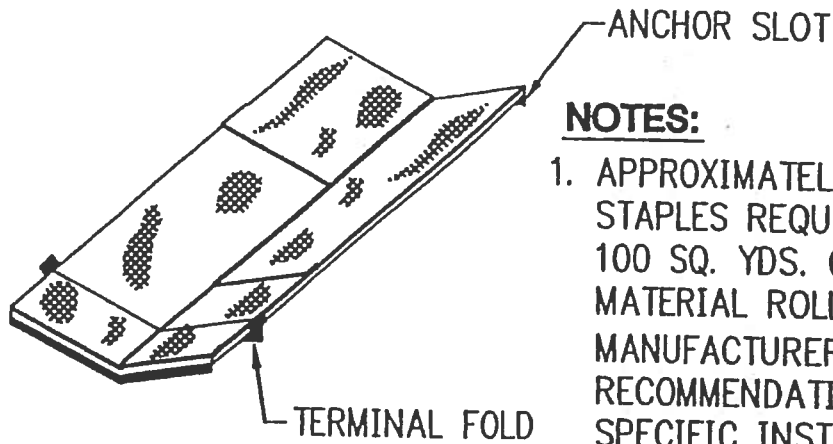

NOTES:

1. APPROXIMATELY 200 STAPLES REQUIRED PER 100 SQ. YDS. OF MATERIAL ROLL. CHECK MANUFACTURER'S RECOMMENDATIONS FOR SPECIFIC INSTALLATION AND STAPLING REQUIREMENTS.

12" MAX. 4H:1V OR FLATTER

6" MAX. STEEPER THAN 4H:1V

OVERLAP ENDS AND EDGES A MINIMUM OF 6 INCHES AND STAPLE EVERY 6 INCHES

5' MAX. 4H:1V OR FLATTER

3' MAX. STEEPER THAN 4H:1V

CHECK SLOT *

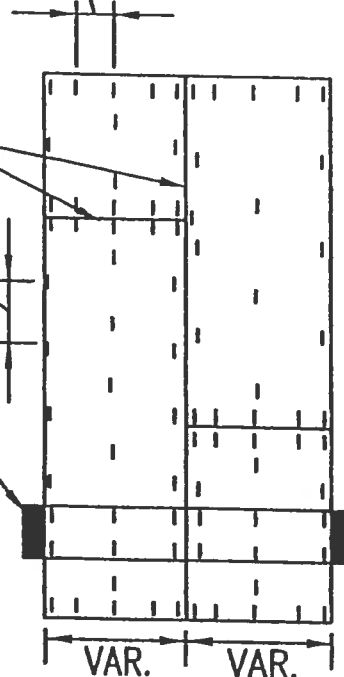

PLAN VIEW

STAPLING DIAGRAM:

* CHECK SLOTS AT MIN. 50' INTERVALS; NOT REQ'D WITH ALL "COMBINATION" BLANKETS.

SD11 EROSION CONTROL BLANKET (continued)

TYPICAL ORIENTATION

SHALLOW SLOPE:

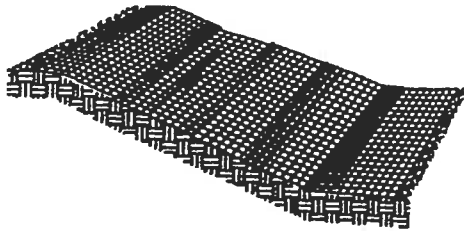

ON SHALLOW SLOPES, STRIPS OF PROTECTIVE COVERINGS MAY BE APPLIED PARALLEL TO DIRECTION OF FLOW.

BERM:



WHERE THERE IS A BERM AT THE TOP OF THE SLOPE, BRING THE MATERIAL OVER THE BERM AND ANCHOR IT BEHIND THE BERM.

STEEP SLOPE:

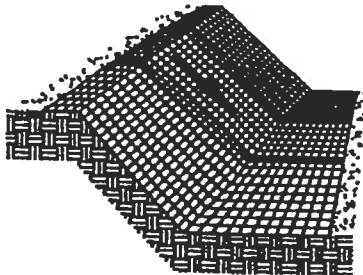

ON STEEP SLOPES, APPLY PROTECTIVE COVERING PERPENDICULAR TO THE DIRECTION OF FLOW AND ANCHOR SECURELY.

STEEP SLOPE:

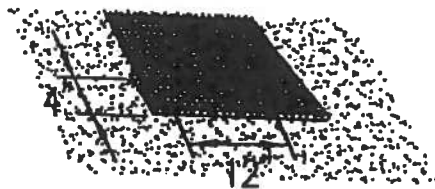

BRING MATERIAL DOWN TO A LEVEL AREA BEFORE TERMINATING INSTALLATION. TURN THE END UNDER 4" AND STAPLE AT 12" INTERVALS.

DITCH:

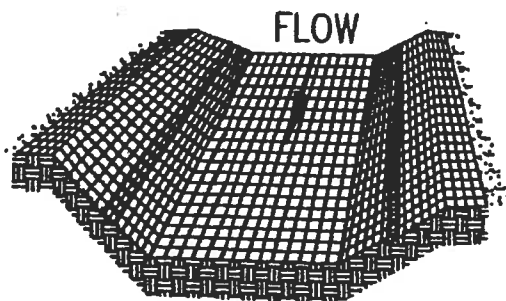

IN DITCHES, APPLY PROTECTIVE COVERING PARALLEL TO THE DIRECTION OF FLOW. AVOID JOINING MATERIAL IN THE CENTER OF THE DITCH IF AT ALL POSSIBLE.

SD11 EROSION CONTROL BLANKET (continued)

LAYING AND STAPLING:

Place the erosion control blanket on a friable seedbed free of clods, rocks, and roots that might impede good contact.

1. Start placing the protective covering from the top of the channel or slope and unroll down-grade.
2. Allow to rest loosely on soil; do not stretch.
3. Upslope ends of the protective covering should be buried in an anchor slot no less than 6 inches deep. Tamp earth firmly over the material. Staple the material at a minimum of every 12 inches across the top end.
4. Edges of the material shall be stapled every 3 feet. The multiple widths are placed side by side, the adjacent edges shall be overlapped a minimum of 6 inches and stapled together. Staples shall be placed down the center, staggered with the edges at 3 foot intervals.

NOTE:

Study manufacturer's recommendations and site conditions for correct installation and stapling of product.

SD11 EROSION CONTROL BLANKET (continued)

JOINING PROTECTIVE COVERINGS:

Insert a new roll of material into an anchor slot as with upslope ends. Overlap the end of the previous roll a minimum of 12 inches, and staple across the end of the roll just below the anchor slot and across the material every 12 inches.

TERMINAL END:

Where the material is discontinued or where the ends under 4 inches, and staple across end every 12 inches.

AT BOTTOM OF SLOPES:

Roll onto a level surface before anchoring, turn ends under 4 inches, and staple across end every 12 inches.

FINAL CHECK:

These installation criteria must be met:

1. Protective blanket is in uniform contact with the soil.
2. All lap joints are secure.
3. All staples are driven flush with the ground.
4. All disturbed areas have been seeded.

MAINTENANCE:

All soil stabilization blankets and matting should be inspected periodically following installation, particularly after storms, to check for erosion and undermining. Any dislocation or failure should be repaired immediately. If washouts or breakage occurs, reinstall the material after repairing damage to the slope or ditch. Continue to monitor these areas until they become permanently stabilized; at that time an annual inspection should be adequate.

SD12 SODDING

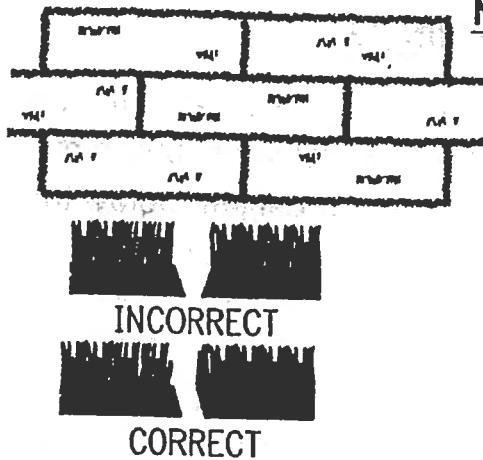

NOTE:

LAY SOD IN A STAGGERED PATTERN. BUTT THE STRIPS TIGHTLY AGAINST EACH OTHER. DO NOT LEAVE SPACES AND DO NOT OVERLAP. A SHARPENED MASON'S TROWEL IS A HANDY TOOL FOR TUCKING DOWN THE ENDS AND TRIMMING PIECES.

BUTTING:

ANGLED ENDS CAUSED BY THE AUTOMATIC SOD CUTTER MUST BE MATCHED CORRECTLY.

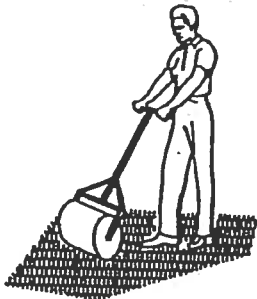

ROLL SOD IMMEDIATELY TO ACHIEVE FIRM CONTACT WITH THE SOIL.

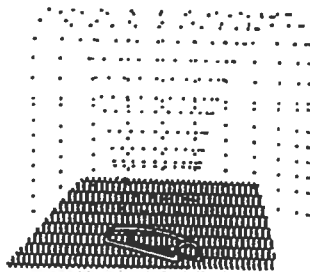

WATER SOD TO A DEPTH OF 4" AS NEEDED. WATER WELL AS SOON AS THE SOD IS INSTALLED.



MOW WHEN THE SOD IS ESTABLISHED - IN 2-3 WEEKS. SET THE MOWER HEIGHT AT 2"-3".

APPEARANCE OF GOOD SOD:

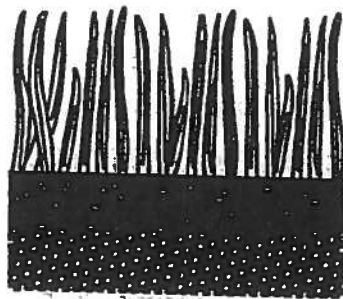

SHOOTS:

GRASS SHOULD BE GREEN AND HEALTHY, MOWED AT A 2"-3" CUTTING HEIGHT.

THATCH:

GRASS CLIPPINGS AND DEAD LEAVES UP TO 1/2" THICK.

ROOT ZONE:

SOIL AND ROOTS SHOULD BE 1/2" - 3/4" THICK WITH DENSE ROOT MAT FOR STRENGTH.

SD12 MULCHING

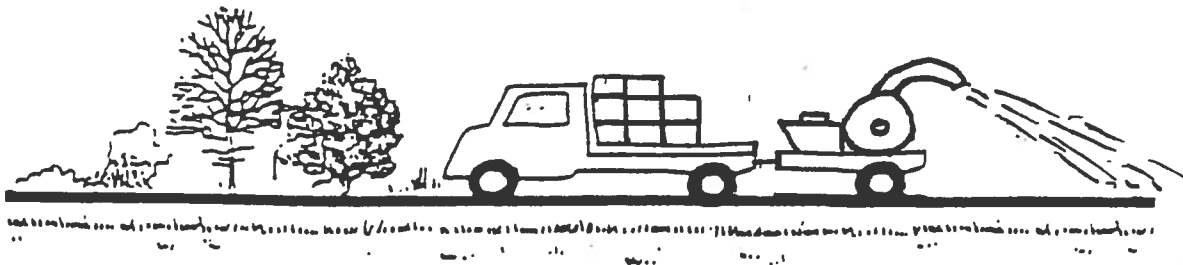

DEFINITION

The application of plant residues and other suitable materials to the soil surface.

PURPOSE

The purpose of this practice is as follows:

1. To prevent erosion and prevent surface compaction or crusting by protecting the soil surface from raindrop impact and reducing the velocity of overland flow.
2. To foster the growth of vegetation by conserving available moisture and providing insulation against extreme heat and cold.
3. To improve the aesthetics of the site.
4. To control weeds.

CONDITIONS WHERE PRACTICE APPLIES

Temporary Mulches:

1. Areas that have been seeded to provide a temporary or permanent seeding.
2. Areas that cannot be seeded because of the season of the year and need for soil surface protection.
3. For mud and dust control.
4. Provide protection during periods when construction or seeding cannot be done.

Permanent Mulches:

1. Used together with planting trees, shrubs, and other ground covers which do not provide adequate soil stabilization.
2. Used in lieu of vegetative planting for ornamental reasons or because the site is not suitable for vegetation.

CRITERIA

A. The choice of materials will be based on the type of soil to be protected, season and economics.

B. Prior to Application

1. Shape and grade as required, the waterway, channel, slope, or other area to be protected.
2. Remove all rocks, clods, or debris larger than 2 inches in diameter that will prevent contact between the mulch and the soil surface.
3. When open-weave nets are used, lime, fertilizer, and seed may be applied either before or after laying the net. When excelsior matting is used. These materials must be applied before the mat is laid.

C. Time of Application

1. Immediately after seeding or planting by conventional method or hydroseeding. Can be applied with seeding as hydromulching.

SD12 MULCHING (continued)

2. Immediately after seedbed preparation when dormant seedings are to be made by seeding over the mulch.

3. When temporary erosion control is to be attained, mulch may be applied any time soil and site conditions are suitable for spreading and anchoring.

D. Application: Mulch materials shall be spread uniformly, by hand or machine. When spreading straw mulch by hand, divide the area to be mulched into approximately 1,000 sq. ft. sections and place approximately 90 lbs. of straw in each section to facilitate uniform distribution.

E. Mulch Anchoring: Straw mulch shall be anchored immediately after spreading to prevent windblow. One of the following methods of anchoring straw shall be used:

1. Mulch anchoring tool: This is a tractor-drawn implement (mulch crimper, serrated straight disk, or dull farm disk) designed to punch mulch approximately 2 inches into the soil surface. This method provides maximum erosion control with straw. It is limited to use on slopes no steeper than 3:1, where equipment can operate safely. Machinery shall be operated on the contour.

2. Liquid mulch binders: Application of liquid mulch binders and tackifiers should be heaviest at edges of areas and at crests of ridges and banks, to prevent windblow. The remainder of the area should have binder applied uniformly. Binders may be applied after mulch is spread; however, it is recommended to be sprayed into the mulch as it is being blown onto the soil. Applying straw and binder together is the most effective method.

The following types of binders may be used:

a. Asphalt--Any type of asphalt thin enough to be blown from spray equipment is satisfactory. Recommended for use are rapid curing (RC-70, RC-250, RC-800), medium curing (MC-250, MC-800) and

emulsified asphalt (SS-1, MS-2, RS-1, and RS-2).

b. Synthetic binders--Chemical binders may be used as recommended by the manufacturer to anchor mulch. These are expensive, and therefore, usually used in small areas or in residential areas where asphalt may be a problem.

c. Wood Fiber--Wood fiber hydroseeder slurries may be used to tack straw mulch. This combination treatment is well suited to steep slopes and critical areas, and severe climate conditions.

3. Mulch nettings--Lightweight, degradable, plastic, polyester, or paper nets may be stapled over the mulch according to manufacturer's recommendations.

4. Peg and twine--Because it is labor-intensive, this method is feasible only in small areas where other methods cannot be used. Drive 8 to 10-inch wooden pegs to within 3 inches of the soil surface, every 4 feet in all directions. Stakes may be driven before or after straw is spread. Secure mulch by stretching twine between pegs in a criss-cross-within-a-square pattern. Turn twine 2 or more times around each peg.

Chemical Mulches - Chemical mulches may be used alone only in the following situations:

1. Where no other mulching material is available.
2. In conjunction with temporary seeding during the times when mulch is not required for that practice.

Note: Chemical mulches may be used to bind other mulches or with wood fiber in a hydroseeded slurry at any time. Manufacturer's recommendations for application of chemical mulches shall be followed.

Nets and Mats - Nets may be used alone on level areas, on slopes no steeper than 3:1, and in waterways.

When mulching is done in late fall or during June, July, and August, or where soil is highly erodible, nets

SD12 MULCHING (continued)

should only be used in conjunction with an organic mulch such as straw.

When nets and organic mulch are used together, the net should be installed over the mulch except when the mulch is wood fiber. Wood fiber may be sprayed on top of the installed net.

Excelsior blankets are considered protective mulches and may be used alone on erodible soils and during all times of year.

Other products designed to control erosion shall conform to manufacturer's specification and should be applied in accordance with manufacturer's instructions provided those instructions are at least as stringent as this specification.

Laying the Net:

1. Start laying net from top of channel or top of slope and unroll down-grade. Always lay netting in the direction of water flow.
2. Allow to lay loosely on soil--do not stretch.
3. To secure net: Upslope ends of net should be buried in a slot or trench no less than 6 inches deep. Tamp earth firmly over net. Staple the net every 12 inches across the top end. Edges of net shall be stapled every 3 feet. Where 2 strips of net are laid side by side, the adjacent edges shall be overlapped 3 inches and stapled together.

Staples will be made of plain iron wire, No. 8 gauge or heavier, and will be 6 inches or more in length. Staples shall be placed down the center of net strips at 3-foot intervals. **DO NOT STRETCH** net when applying staples.

Joining strips: Insert new roll of net in trench, as with upslope ends of net. Overlap the end of the previous roll 18 inches, turn under 6 inches, and staple across end of roll just below anchor slot and at the end of the turned-under net every 12 inches.

At bottom of slopes: Extend net out onto a level area before anchoring.

Turn ends under 6 inches, and staple across end every 12 inches.

Check slots: On highly erodible soils and on slopes steeper than 4:1, erosion check slots should be made every 15 feet. Insert a fold of net into a 6-inch trench and tamp firmly. Staple at 12-inch intervals across the downstream portion of the net.

Rolling: After installation, stapling, and seeding, the net should be rolled to ensure firm contact between net and soil.

CONSIDERATIONS

1. A surface mulch is one of the most effective means of controlling runoff and erosion on disturbed lands.
2. The choice of materials for mulching shall be based on the type of soil to be protected, site conditions, season, and economics.
3. Organic mulch materials such as straw, wood chips, bark, and wood fiber have been found to be the most effective.
4. Chemical soil stabilizers or soil binders are not effective mulches when used alone. These materials are useful to bind organic mulches together.
5. A variety of mulch nets, mats, or blankets are available to use as mulching or to hold the mulch in place. Netting and mats are especially helpful on critical areas such as waterways.

Organic Mulches:

Straw - The mulch most commonly used in conjunction with seeding. The recommended straw should come from oats, wheat, rye or barley, and may be spread by hand or machine. Straw can be windblown and should be anchored to stay in place.

Wood Chips - Suitable for areas that will not be closely mowed, and around ornamental plantings. Chips decompose slowly and do not require tacking. They should be treated with 12 pounds nitrogen per ton to prevent nutrient deficiency in plants. They also

SD12 MULCHING (continued)

can be a very inexpensive mulch if obtained from trees cleared on the site.

Bark Chips, Shredded Bark - By-products of timber processing. They are often used in landscaped plantings. Bark is also a suitable mulch for areas planted to grasses and not closely mowed ; and may be applied by hand or mechanically. Bark is not usually toxic to grasses or legumes, and additional nitrogen fertilizer is not required.

There are other organic materials which make excellent mulches but are only available locally or seasonally. Creative use of these materials can reduce costs.

Chemical Mulches and Soil Binders:

A wide range of synthetic, spray-on materials are marketed to stabilize and protect the soil surface. These are emulsions or dispersions of vinyl compounds, asphalt, rubber, or other substances which are mixed with water and applied to the soil. They may be used alone or may be used to tack wood fiber hydromulches or straw.

When used alone, chemical mulches do not have the capability to insulate the soil or retain soil moisture that organic mulches have. This soil protection is also damaged by traffic. Application of these mulches is usually more expensive than organic mulching, and the mulches decompose in 60-90 days.

Nets and Mats:

When used alone, netting does not retain soil moisture or modify soil temperature. It stabilizes the soil surface while grasses are being established, and is useful in grassed waterways and on slopes. Light netting may also be used to hold other mulches in place.

The most critical aspect of installing nets and mats is obtaining firm, continuous contact between the material and the soil. Without such contact, the material is useless and erosion occurs. It is important to use an adequate number of staples and to

roll the material after laying it to ensure that the soil is protected.

Aggregate Cover - Gravel and crushed stone provide a long term protection against erosion, particularly on short slopes. Before the gravel or crushed stone is applied it should be washed. If vegetation is not desired, black polyethylene sheeting should be placed on the ground first to prevent seed germination and growth through the aggregate cover.

PLANS AND SPECIFICATIONS

Plans and specifications for applying mulch shall be in keeping with this standard and shall describe the requirements for applying the practice. Include the following items:

1. Materials to be used.
2. How mulch will be anchored.
3. Location of different materials if more than one material is used on the site.

OPERATION AND MAINTENANCE

All mulches should be inspected periodically, in particular after rainstorms, to check for rill erosion. Where erosion is observed, additional mulch should be applied. Nets should be inspected after rainstorms for dislocation or failure. If washouts or breakage occur, re-install netting as necessary after repairing damage to the slope. Inspections should occur until grasses are firmly established. Where mulch is used in conjunction with ornamental plantings, inspect periodically throughout the year to determine if mulch is maintaining coverage of the soil surface; repair as needed.

SCS-URB

December 1994

urb875.dcx

SD14 PERMANENT SEEDING



DEFINITION

Establishing permanent vegetative cover to stabilize disturbed areas.

PURPOSE

The purpose of this practice is to reduce erosion and decrease sediment from disturbed areas, and to permanently stabilize such areas in a manner that adapts to site conditions and allows selection of the most appropriate plant materials.

CONDITIONS WHERE PRACTICE APPLIES

1. Disturbed areas where long-lived vegetative cover is needed to stabilize the soil.
2. On other areas where cover is desired.

CRITERIA

Selection of plant materials - Selection of plant materials will be based on climate, topography, soils, landuse, available light, aesthetics and maintenance. See tables A, B and C for selection of grasses and legumes and ground covers. For trees and shrubs see practice standard 985, TREE AND SHRUB PLANTING.

Site Preparation - The soil must meet minimum requirements as a good growth medium.

a. Must have enough fine-grained (silt & clay) material to maintain adequate moisture and nutrient supply and sufficient pore space to permit root penetration. The bulk density should be 1.2 to 1.5 grams per cubic centimeter. Clay content should not exceed 35 percent.

b. The depth of suitable rooting material to rock or impermeable layers shall be 12 inches or more, except on steep slopes where adding soil material is not feasible.

c. A pH range of 5.5 to 6.5

d. Be free of toxic amounts of materials harmful to plant growth.

If any of the above criteria cannot be met by the addition of modifying materials, ie: lime or organic material, then topsoil shall be applied in accordance with practice standard 981 TOPSOILING.

The following materials may be used where needed to improve the soil conditions for plant growth.

Peat-Appropriate types are sphagnum moss peat, hypnum moss peat, reedsedge peat, or peat humus from fresh water sources.

Sand-clean and free of toxic materials.

SD14 PERMANENT SEEDING (continued)

Vermiculite-horticultural grade and free of toxic substances.

Rotted manure-stable or cattle manure not containing undue amounts of straw or other bedding materials. Incorporate to reduce potential odor problems.

Thoroughly rotted sawdust-free of stones and debris.

Sludge- treated sewage and industrial sludges should be used only in accordance with local, state and federal regulations.

Where extensive excavation is to be done and the subsoil materials will not be suitable for plant growth, remove and stockpile existing topsoil and re-apply when final grade is achieved.

Install necessary mechanical erosion and sedimentation control practices before seeding, and complete grading according to the approved plan.

Seedbed preparation:

1. Apply fertilizer and other required soil amendments prior to final seedbed preparation.

2. Prepare a seedbed to a minimum depth of 3 inches by disking or other suitable means. All tillage operations should be on the contour.

Fertilization - Lime and fertilizer needs should be determined by soil tests. When soil tests are not available, apply 1000 pounds per acre or 25 pounds per 1000 square feet of 12-12-12 fertilizer or equivalent.

Seed - Certified seed will be used for all permanent seedings whenever

possible. All legumes will be inoculated with the proper inoculant prior to seeding.

Seeding - Seeding may be done by any of the following methods:

A. Conventional

1. Prepare seedbed and incorporate lime and fertilizer.

2. Apply seed uniformly at a depth of 1/4 to 1/2 inch with a drill (band seed) or cultipacker seeder or broadcast seed uniformly and cover to 1/4 to 1/2 inch depth with a cultipacker, or similar tool.

3. Mulch following seeding.

B. Hydroseeding

1. Final seedbed preparation should leave the soil surface in a roughened condition.

2. Lime and fertilizer should be incorporated prior to seeding unless they are to be applied at the same time of the seed. (applying lime with a hydroseeder may be abrasive to the equipment).

3. No less than 1000 gallons of water per acre will be used.

4. When seeding legumes, increase the recommended rate for inoculant four times.

5. If seed and fertilizer are mixed together they should be seeded within 2 hours of mixing. Beyond 2 hours, a full rate of new seed may be necessary.

6. Cultipacking or harrowing following seeding will help insure a better stand.

C. Dormant seeding may be made between November 15 and March 1 by either of the following methods:

SD14 PERMANENT SEEDING (continued)

1. Conventional Method - If soil conditions are suitable during the dormant seeding period, apply lime and fertilizer, prepare the seedbed and seed as specified in this specification. Increase the seeding rate at least 50%. Mulch following seeding.

2. Overseeding Method - Liming, fertilizing, seedbed preparation and mulching may be done after August 31. The seed shall be broadcast uniformly over the mulch between November 15 and March 1. When this is done, increase the seeding rates 50%.

Sprigging - Some plants cannot be grown from seed and must be planted vegetatively. Sprigs are fragments of horizontal stems or roots which include at least one node (joint). Sprigs may be planted by either of the following methods.

A. Broadcast sprigs and press into the top 1/2 to 2 inches of soil with a cultipacker or a disk set straight so that the sprigs are not brought back toward the surface.

B. Make furrows 4-6 inches deep and 2 feet apart. On sloping areas, make furrows perpendicular to the slope (on the contour). Place sprigs in the furrows with one end at or above ground level. Close the furrow when plants have been placed.

C. Plant sprigs in furrows with a tractor-drawn transplanter. Sprigging should be done during specified seeding periods.

Planting ground covers - Most shrub and vine type ground covers are available as bare root stock, balled and burlapped, or in containers or pots. On flat areas where erosion is not a problem, prepare the site by tilling to a depth of 10-12 inches.

On sloping sites, till 2 - 3 inches deep to incorporate needed soil amendments.

When planting individual plants, prepare a hole slightly larger than the container or ball and deep enough that the roots can extend to the bottom. Most ground covers should be planted 1/2" to 1" deeper than they have grown in the pot or container.

Mulching - All permanent seedings and plantings will be mulched upon completion of seed application or planting. Refer to practice standard 875, **MULCHING**. When planting ground covers it may be advantageous to mulch prior to planting.

CONSIDERATIONS

Protect the area from excess runoff as necessary with diversions, grass-lined channels, terraces, or sediment basins.

Evaluate the capabilities and limitations of the soil to be seeded or planted. Special attention needs to be given to soil pH, texture, internal water movement, steepness, and stability in order to plan the appropriate treatment.

Plant species should be selected on the basis of soil type, planned use of the area, and the amount or degree of maintenance that can be devoted to the area in the future. Consideration should be given to using native vegetation where possible. Landuse and maintenance, whether residential, industrial, commercial or recreational, can be divided into two general categories:

High-maintenance areas are mowed frequently, limed and fertilized regularly, and either (1)

SD14 PERMANENT SEEDING (continued)

receive intensive use (e.g., athletic fields or golf courses) or (2) require maintenance to an aesthetic standard (e.g., home lawns). Grasses or ground covers used for these situations are long-lived perennials that form a tight sod and are fine-leaved and attractive in appearance. They must be well adapted to the geographic area where they are planted and able to endure the stress of frequent mowing. Sites where high-maintenance vegetative cover is desirable include homes, industrial parks, schools, churches, and recreational areas.

Low-maintenance areas are mowed infrequently or not at all, and do not receive lime and fertilizer on a regular basis. Plants must persist with little maintenance over long periods of time. Grass and legume mixtures are favored for these sites because legumes are a source of soil nitrogen. Mixed stands are also more resistant to adverse conditions. Prairie grass may be appropriate but are slow to establish. Sites suitable for low-maintenance vegetation include steep slopes, stream or channel banks, some commercial properties and roadbanks.

Fertilizer, lime, seedbed preparation, seed coverage, mulch, and irrigation should be used as necessary to promote quick plant growth.

Vegetation cannot be expected to provide erosion control cover and prevent soil slippage on a soil that is not stable due to its structure, water movement, or excessive slope.

The operation of equipment is restricted and may be unsafe on slopes steeper than 3:1. Where steepness prohibits the use of farm machinery, seedbed preparation, fertilization, and seeding or planting may need to be done by hand.

Mulching, in addition to preventing erosion during establishment, may make the difference in success or failure of the seeding. When selecting mulching materials, consider steepness and length of slopes, areas of concentrated runoff water flow, and materials that will provide protection to the site in case the seeding or planting fails.

Moisture is essential for seed germination and seedling establishment. Supplemental irrigation can be very helpful in assuring adequate stands in dry seasons or to speed development of full cover.

PLANS AND SPECIFICATIONS

The plans and specifications for seeding or planting and mulching shall include the following items:

1. Seeding mixtures and rates or plant species and density.
2. Site preparation.
3. Fertilization.
4. Seeding or planting methods.
5. Seeding or planting periods.
6. Mulching materials and application rates.
7. Schedule for installation, inspection and maintenance.

OPERATION AND MAINTENANCE

Generally, a stand of vegetation cannot be determined to be fully established until soil cover has been maintained for one full year from planting.

Protect the planted area from human, animal and vehicular traffic until the stand is adequately established.

Inspect all planted areas for failures and make necessary repairs, replacements, reseeding, and

SD14 PERMANENT SEEDING (continued)

remulching within the planting season, if possible. If a stand has less than 40% cover, re-evaluate the choice of plant materials, quantities of lime and fertilizer, seeding or planting methods, time of seeding or planting and available light and moisture. Re-establish the stand following the original specifications, but with modifications based on the evaluation.

Where an adequate water supply is available, irrigate to keep the seedbed moist (not wet) for 7 to 10 days after seeding. This may require watering daily the first week, especially during hot weather, and less frequently thereafter. Water application rates must be carefully controlled to prevent runoff and erosion. Inadequate or excessive amounts of water can be more harmful than no supplemental water. Irrigation is seldom needed for low-maintenance seedings made at the appropriate time of the year.

Both low and high-maintenance seedings should be fertilized one year after planting to strengthen the plants and insure proper stand density. The following recommendations may be used:

1. For grass only stands, apply 500 lbs./acre (12 lbs/1000 sq. ft.) of 10-20-10, or equivalent.
2. For grass-legume or pure legume stands, apply 500 Lbs/ac. (12 lbs./1000 sq. ft.) of 10-20-20, or equivalent.
3. The best time to apply fertilizer is between March 1 and May 30 or August 1 and September 30.

Do not mow high-maintenance turf seedings until the stand is at least 6 inches tall. Do not mow closer than 3 inches during the year of establishment.

Low-maintenance stands should be mowed only as needed to control weeds. Mowing should be done

before weeds go to seed. Keep mowing height above the height of the seeded plants. Vine and shrub type ground covers may need hand weeding until the area is well covered.

Herbicides may also be used for weed control. Apply all herbicides according to rates specified on the label.

SCS IL
urb880.dcx

December 1994

SD14 PERMANENT SEEDING (continued)

Table A
LOW MAINTENANCE GRASSES AND LEGUMES

D	Site Suitability		Sun Light Availability			Seed Mixture	Seeding Rates (PLS)	
	WD	W	FS	PS	S		lbs/Ac.	lbs/1000 sq./ft.
X	X		X			Smooth bromegrass or tall fescue plus Alfalfa or birdsfoot trefoil	24	.55
X	X		X	X		Smooth bromegrass or tall fescue plus Crownvetch	24 16	.55 .20
X	X	X	X			Tall fescue plus Timothy or redtop Birdsfoot trefoil	12 2.5 12	.30 .06 .30
X	X	X	X			Switchgrass <u>1/</u>	8	.20
X	X		X			Switchgrass <u>1/</u> plus Big Blue plus Indianagrass	2 6 6	.04 .14 .14

1/ Warm season grasses

D = Droughty FS = Full Sun
 WD = Well Drained PS = Partial Sun
 W = Wet S = Shady

SD14 PERMANENT SEEDING (continued)

**TABLE B
HIGH MAINTENANCE SEED MIXTURES**

Site Suitability			Sun Light Availability			Seed Mixture	Seeding Rates (PLS)	
D	WD	W	FS	PS	S		lbs/Ac.	lbs/1000 sq./ft.
X	X		X	X		Ky bluegrass Use at least 3 adapted varieties	88-130	2-3
X	X			X		Ky bluegrass plus Red fescue	110 44	2.5 1.0
X	X	X	X	X	X	Tall fescue (turf type)	220-260	5-6
X	X			X	X	Red fescue plus Ky bluegrass	110 44	2.5 1
X	X		X	X		Ky bluegrass plus Perennial ryegrass	86 43	2.0 1.0

D = Droughty FS = Full Sun
 WD = Well Drained PS = Partial Sun
 W = Wet S = Shady

SEEDING DATES

SPRING

Northern Illinois Early Spring to June 1
 Central Illinois Early Spring to May 15
 Southern Illinois Early Spring to May 15

FALL

Northern Illinois August 1 to September 1
 Central Illinois August 1 to September 10
 Southern Illinois August 1 to September 20

DORMANT

Northern Illinois November 1 to March 15
 Central Illinois November 15 to March 1
 Southern Illinois November 15 to March 1

SD14 PERMANENT SEEDING (continued)

TABLE C.

GROUND COVERS (Shrubs & Vines)

This table contains a list of ground covers commonly used in Illinois. When selecting species to use, check with a local nursery for availability of plants, growth characteristics and recommended spacings.

Bugle
 Wild Ginger
 Barberry
 Dwarf quince
 Crownvetch
 Creeping cotoneaster 4" - 2' prostrate
 Mock strawberry
 Euonymus - several species (Wintercreeper) Evergreen
 English ivy
 Daylilly
 Evergreen candytuff
 Juniper (Creeping)
 Pachysandra (Japanese spurge)
 Creeping phlox
 Shrubby cinquefoil (Potentilla)
 Dwarf alpine current
 Stonedrop (Sedum)
 Creeping thyme
 Common periwinkle (Vinca)

SCS IL

urb880

SD15 PUMP DISCHARGE FILTER BAG

DIRTBAG® PUMP-SILT CONTROL SYSTEM NOTES:

A) GENERAL NOTES:

1. THE DIRTBAG® WILL HAVE AN OPENING LARGE ENOUGH TO ACCOMMODATE A 4" DISCHARGE HOSE WITH ATTACHED STRAP TO TIE OFF THE HOSE TO PREVENT THE PUMPED WATER FROM ESCAPING THE DIRTBAG® WITHOUT BEING FILTERED.
2. INSTALL THE DIRTBAG® ON A SLOPE. IT SHOULD BE PLACED SO THE INCOMING WATER FLOWS THROUGH THE DIRTBAG® SHOULD BE TIED OFF TIGHTLY TO STOP THE WATER FROM FLOWING OUT OF THE OPENING WITHOUT BEING FILTERED THROUGH THE FABRIC TO INCREASE THE EFFICIENCY OF THE FILTRATION, THE BAG SHOULD BE PLACED ON AN AGGREGATE BED TO ALLOW WATER TO FLOW THROUGH ALL SURFACES OF THE BAG.
3. DISPOSAL MAY BE ACCOMPLISHED AS DIRECTED BY THE ENGINEER. IF THE SITE ALLOWS, THE DIRTBAG® MAY BE CUT OPEN AND SEDED, REMOVING THE VISIBLE FABRIC. THE DIRTBAG® IS STRONG ENOUGH TO BE LIFTED IF IT MUST BE HAULED AWAY. IF THE JOBSITE REQUIRES THE DIRTBAG® TO BE RELOCATED TO LANDFILL FOR DISPOSAL, IT MAY BE HELPFUL TO PLACE THE DIRTBAG® IN THE BACK OF A DUMP TRUCK OR FLATBED PRIOR TO USE, ALLOWING THE WATER TO DRAIN WITH BAG IN PLACE, THEREBY DISMISSING THE NEED TO LIFT THE DIRTBAG®.

B) INSPECTION AND MAINTENANCE:

1. THE DIRTBAG® SHOULD BE CONSIDERED FULL WHEN IT IS IMPRACTICAL FOR THE BAG TO FILTER OUT SEDIMENT AT A REASONABLE RATE, AND SHOULD BE REPLACED WITH A NEW DIRTBAG®.

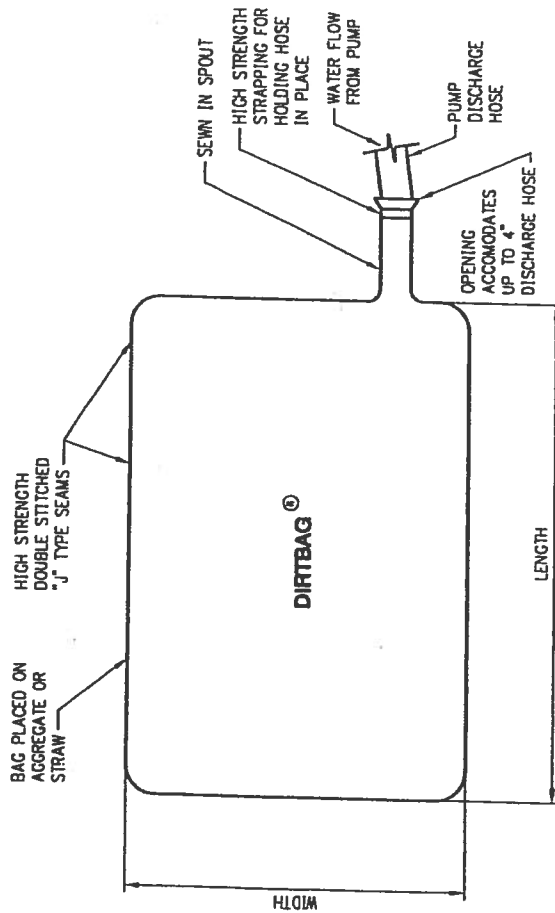

TOP VIEW

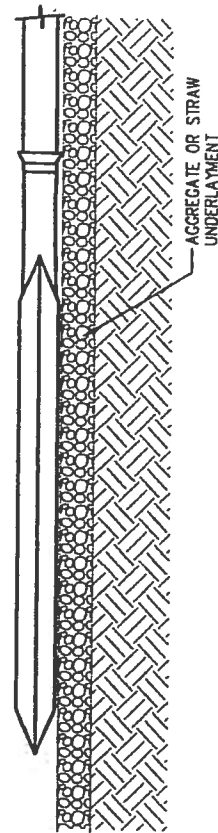

SIDE VIEW

Other products may be submitted for review and approval

SD16 CONCRETE WASHOUT FACILITY

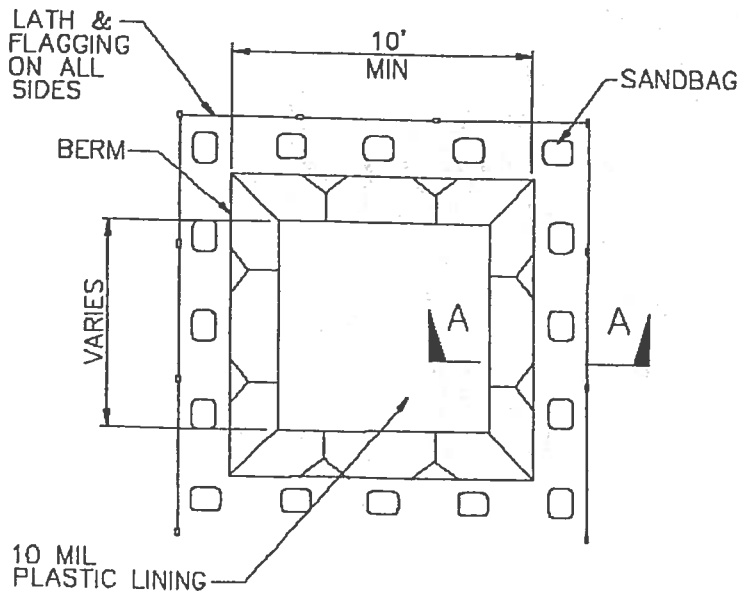

PLAN
NOT TO SCALE
TYPE "BELOW GRADE"

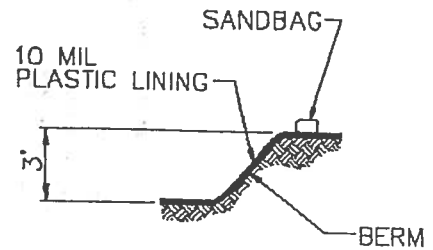

SECTION A-A
NOT TO SCALE

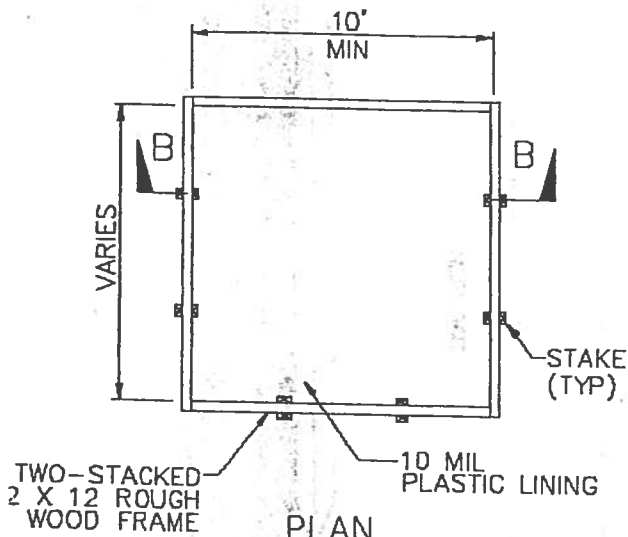

PLAN
NOT TO SCALE
TYPE "ABOVE GRADE"

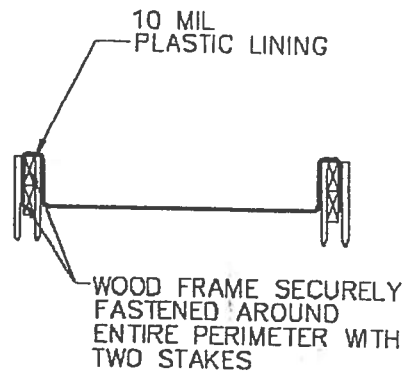

SECTION B-B
NOT TO SCALE

NOTES

1. ACTUAL LAYOUT DETERMINED IN FIELD.
2. THE CONCRETE WASHOUT SIGN SHALL BE INSTALLED WITHIN 30 FT. OF THE TEMPORARY CONCRETE WASHOUT FACILITY.

SD16 CONCRETE WASHOUT FACILITY (continued)

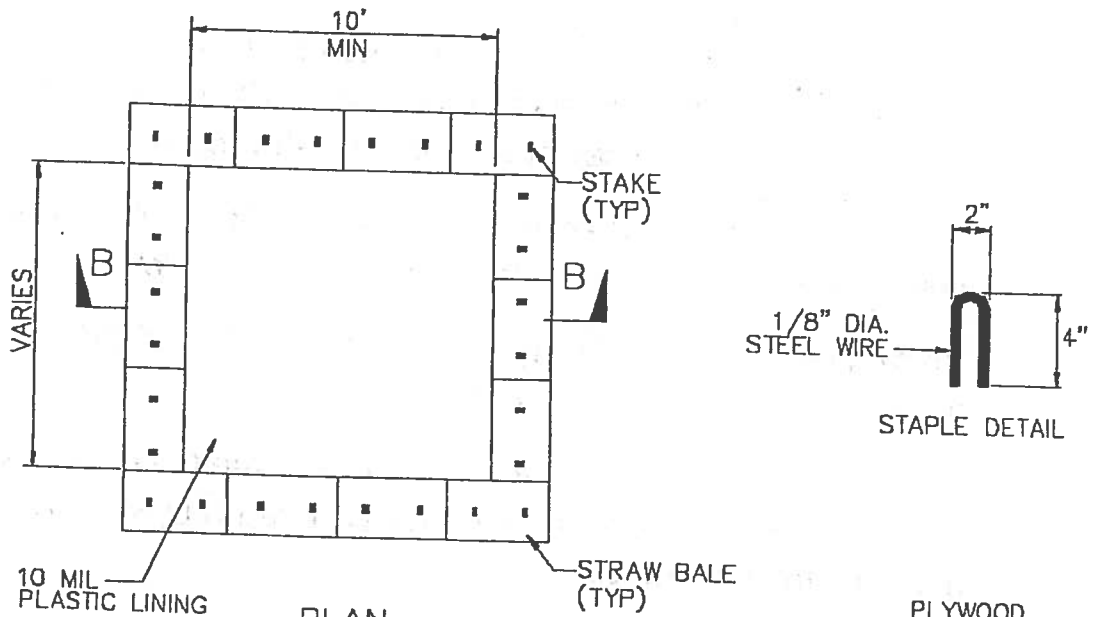

PLAN
NOT TO SCALE
TYPE "ABOVE GRADE"
WITH STRAW BALES

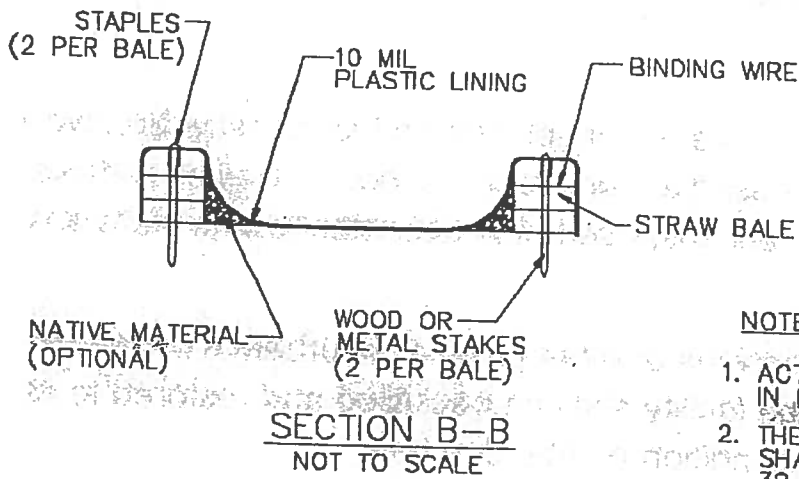
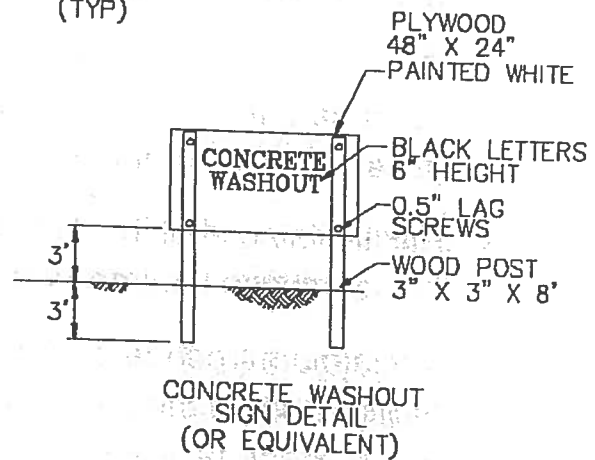

NOTES

1. ACTUAL LAYOUT DETERMINED IN FIELD.
2. THE CONCRETE WASHOUT SIGN SHALL BE INSTALLED WITHIN 30 FT. OF THE TEMPORARY CONCRETE WASHOUT FACILITY.

SD16 CONCRETE WASHOUT FACILITY (continued)

GENERAL

- PCC and AC wastes shall be collected and disposed of or placed in a concrete washout facility. No PCC or AC wastes shall enter the storm sewer system or watercourses.
- Sign shall be installed adjacent to each facility to inform concrete equipment operators to utilize proper facilities.
- Below grade facilities are typical. Above grade facilities are utilized if excavation is not practical.
- Washout facilities shall have sufficient volume to contain all liquid and waste concrete materials generated by washout and construction activities.
- Once concrete wastes are discharged to facility and allowed to harden, the concrete waste should be broken up and disposed of in accordance with state and local law.
- Plastic lining shall be free of holes, tears, or other defects that comprise the impermeability of the material.
- A minimum freeboard 12-inches is required for below grade facilities and a minimum of 4-inches freeboard is required for above grade facilities.

REMOVAL

- When facilities are no longer required for construction work, the materials used to construct the facility shall be removed from the site and disposed of in accordance with state and local law.
- Holes, depressions or other ground disturbance caused by removal of the facility shall be backfilled and restored to its pre-existing condition or intended use.

SD16 CONCRETE WASHOUT FACILITY (continued)

MAINTENANCE

- Facilities must be cleaned or new facilities constructed once the washout is 75% full.
- Remove and dispose of hardened concrete materials to return facilities to a functional condition.
- Inspect washout facility on a weekly basis.

NOTES